



DES-5024 Fast Ethernet Switching System User's Guide

Rev. 01 (January, 1999)

651DES32.K15

Printed In Taiwan



RECYCLABLE

Copyright © 1999 by D-Link Systems, Inc. All rights reserved.

D-Link Limited Warranty

Hardware:

D-Link warrants its hardware products to be free from defects in workmanship and materials, under normal use and service, for the following periods measured from date of purchase from D-Link or its authorized Reseller:

<u>Product Type</u>	<u>Warranty Period</u>
Complete Products	One year
Spare parts and spare kits	90 days

Your dealer, or your nearest D-Link office, can advise whether a longer period of warranty applies to your purchase, and if so, can provide you a separate certificate of supplemental warranty.

The one-year period of warranty on complete products (or such longer period of warranty as may be offered as to your purchase) applies on condition that the product's Registration Card is filled out and returned to a D-Link office within ninety (90) days of purchase. A list of D-Link offices is provided at the back of this manual, together with a copy of the Registration Card. Failing such timely registration of purchase, the warranty period shall be limited to ninety (90) days.

If the product proves defective within the applicable warranty period, D-Link will provide repair or replacement of the product. D-Link shall have the sole discretion whether to repair or replace, and replacement product may be new or reconditioned. Replacement product shall be of equivalent or better specifications, relative to the defective product, but need not be identical. Any product or part repaired by D-Link pursuant to this warranty shall have a warranty period of not less than 90 days, from date of such repair, irrespective of any earlier expiration of original warranty period. When D-Link provides replacement, then the defective product becomes the property of D-Link.

Warranty service may be obtained by contacting a D-Link office within the applicable warranty period, and requesting a Return Material Authorization (RMA) number. If a Registration Card for the product in question has not been returned to D-Link, then a proof of purchase (such as a copy of the dated purchase invoice) must be provided. If handling of warranty correction is required under special circumstances, you may request special procedure at the time of requesting an RMA number.

After an RMA number is issued, the defective product must be packaged securely in the original or other suitable shipping package to ensure that it will not be damaged in transit, and the RMA number must be prominently marked on the outside of the package. The package must be mailed or otherwise shipped to D-Link with all costs of mailing/shipping/insurance prepaid: D-Link will ordinarily reimburse for mailing/shipping/insurance expenses incurred for return of defective product in accordance with this warranty. D-Link shall never be responsible for any software, firmware, information, data contained in, stored on or integrated with any product returned to D-Link pursuant to this warranty.

Any package returned to D-Link without an RMA number will be rejected and shipped back to you at your expense, and D-Link reserves the right in such case to levy a reasonable handling charge in addition to mailing or shipping costs.

Software:

Warranty service for software products may be obtained by contacting a D-Link office within the applicable warranty period. A list of D-Link offices is provided at the back of this manual, together with a copy of the Registration Card. If a Registration Card for the product in question has not been returned to a D-Link office, then a proof of purchase (such as the dated purchase invoice) must be provided when requesting warranty service. The term "purchase" in this software warranty refers to the purchase transaction and resulting license to use such software.

D-Link warrants that its software products will perform in substantial conformance with the applicable product documentation provided by D-Link with such software product, for a period of ninety (90) days from the date of purchase from D-Link or its Authorized Reseller. D-Link warrants the magnetic media, on which D-Link provides its software product, against failure during the same warranty period. This warranty applies to purchased software, and to replacement

software provided by D-Link pursuant to this warranty, but shall not apply to any update or replacement which may be provided for download via the Internet, or to any update which may otherwise be provided free of charge.

D-Link's sole obligation under this software warranty shall be to replace any defective software product with product that substantially conforms to D-Link's applicable product documentation. You assume responsibility for the selection of appropriate application and system/platform software and associated reference materials. D-Link makes no warranty that its software products will work in combination with any hardware, or any application or system platform software product provided by any third party, except those expressly designated in D-Link's applicable product documentation as being compatible. D-Link's obligation under this warranty shall be a reasonable effort to provide compatibility, but D-Link shall have no obligation to provide compatibility when there is fault in the third-party hardware or software. D-Link makes no warranty that operation of its software products will be uninterrupted or absolutely error-free, and no warranty that all defects in the software product, within or without the scope of D-Link's applicable product documentation, will be corrected.

D-Link Offices for Registration and Warranty Service:

The product's Registration card, provided at the back of this manual, must be sent to a D-Link office. To obtain an RMA number for warranty service as to a hardware product, or to obtain warranty service as to a software product, contact the D-Link office nearest to you.

D-Link Offices to Contact for Warranty Service:

To mail your Registration Card, or to obtain an RMA number or warranty service, see the following address:

In North, Central, and South America:

D-Link Systems Inc.

53 Discovery Drive, Irvine CA 92618

Tel. (1) 949-788-0805 Fax (1) 949-753-7033

In Europe and Israel:

D-Link Europe

Denmark House, Staples Corner, The Broadway, London NW9 7BW, U.K.

Tel. (44)181-203-9900 Fax (44)181-203-6915

In the Middle East (except Israel), Asia, Oceania and Africa:

D-Link Corporation

No. 233-2, 2nd F. Pao Chiao Road, Hsin Tien Taipei, Taiwan

TEL. (886)2-916-1600

Trademarks

Copyright ©1999 D-Link Corporation.

D-Link © is a registered trademark of D-Link Corporation/D-Link Systems, Inc.

All rights reserved, contents may be revised without prior notice.

FlexSWITCH™ is a trademark of D-Link Systems, Inc.

Ethernet is a trademark of Xerox Corporation.

Microsoft Windows is a trademark of Microsoft Corporation.

VT100 is a trademark of Digital Equipment Corporation.
All other trademarks belong to their respective proprietors.

Copyright Statement

No part of this publication may be reproduced in any form or by any means or used to make any derivative such as translation, transformation, or adaptation without permission from D-Link Corporation/D-Link Systems Inc., as stipulated by the United States Copyright Act of 1976.

FCC Warning

This equipment has been tested and found to comply with the limits for a Class A digital device, pursuant to Part 15 of the FCC Rules. These limits are designed to provide reasonable protection against harmful interference when the equipment is operated in a commercial environment. This equipment generates, uses, and can radiate radio frequency energy and, if not installed and used in accordance with this user's guide, may cause harmful interference to radio communications. Operation of this equipment in a residential area is likely to cause harmful interference in which case the user will be required to correct the interference at his own expense.

CE Mark Warning

This is a Class A product. In a domestic environment, this product may cause radio interference in which case the user may be required to take adequate measures.

注意

この装置は、情報処理装置等電波障害自主規制協議会 (VCCI) の基準に基づく第一種情報技術装置です。この装置を家庭環境で使用すると電波妨害を引き起こすことがあります。この場合には使用者が適切な対策を講ずるよう要求されることがあります。

Wichtige Sicherheitshinweise

Bitte lesen Sie sich diese Hinweise sorgfältig durch.

Heben Sie diese Anleitung für den spätem Gebrauch auf.

Vor jedem Reinigen ist das Gerät vom Stromnetz zu trennen. Verwenden Sie keine Flüssig- oder Aerosolreiniger. Am besten dient ein angefeuchtetes Tuch zur Reinigung.

Um eine Beschädigung des Gerätes zu vermeiden sollten Sie nur Zubehörteile verwenden, die vom Hersteller zugelassen sind.

Das Gerät ist vor Feuchtigkeit zu schützen.

Bei der Aufstellung des Gerätes ist auf sichern Stand zu achten. Ein Kippen oder Fallen könnte Verletzungen hervorrufen. Verwenden Sie nur sichere Standorte und beachten Sie die Aufstellhinweise des Herstellers.

Die Belüftungsöffnungen dienen zur Luftzirkulation die das Gerät vor Überhitzung schützt. Sorgen Sie dafür, daß diese Öffnungen nicht abgedeckt werden.

Beachten Sie beim Anschluß an das Stromnetz die Anschlußwerte.

Die Netzanschlußsteckdose muß aus Gründen der elektrischen Sicherheit einen Schutzleiterkontakt haben.

Verlegen Sie die Netzanschlußleitung so, daß niemand darüber fallen kann. Es sollte auch nichts auf der Leitung abgestellt werden.

Alle Hinweise und Warnungen die sich am Geräten befinden sind zu beachten.

Wird das Gerät über einen längeren Zeitraum nicht benutzt, sollten Sie es vom Stromnetz trennen. Somit wird im Falle einer Überspannung eine Beschädigung vermieden.

Durch die Lüftungsöffnungen dürfen niemals Gegenstände oder Flüssigkeiten in das Gerät gelangen. Dies könnte einen Brand bzw. Elektrischen Schlag auslösen.

Öffnen Sie niemals das Gerät. Das Gerät darf aus Gründen der elektrischen Sicherheit nur von autorisiertem Servicepersonal geöffnet werden.

Wenn folgende Situationen auftreten ist das Gerät vom Stromnetz zu trennen und von einer qualifizierten Servicestelle zu überprüfen:

Netzkabel oder Netzstecker sind beschädigt.

Flüssigkeit ist in das Gerät eingedrungen.

Das Gerät war Feuchtigkeit ausgesetzt.

Wenn das Gerät nicht der Bedienungsanleitung entsprechend funktioniert oder Sie mit Hilfe dieser Anleitung keine Verbesserung erzielen.

Das Gerät ist gefallen und/oder das Gehäuse ist beschädigt.

Wenn das Gerät deutliche Anzeichen eines Defektes aufweist.

Bei Reparaturen dürfen nur Originalersatzteile bzw. den Originalteilen entsprechende Teile verwendet werden. Der Einsatz von ungeeigneten Ersatzteilen kann eine weitere Beschädigung hervorrufen.

Wenden Sie sich mit allen Fragen die Service und Reparatur betreffen an Ihren Servicepartner. Somit stellen Sie die Betriebssicherheit des Gerätes sicher.

Table of Contents

Table of Contents	vi
About This Guide	1
Audience	1
Organization	1
1	2
Introduction	2
Features	2
Front Panel	4
Rear Panel	5
Management Methods	6
Local Console Management	6
Telnet Management	6
D-View/ SNMP Management	6
RMON	6
Updating Firmware	6
2	7
Installing the DES-5024	7
Unpacking the DES-5024	7
Installation Options	8
Installing Modules	14
Power On	17
3	18
Connecting the DES-5024 to the Network	18
Cable Specifications	18
Copper Cable	18
Fiber Optic Cable	20
Ports	21
MDI-X Ports	21
Fiber Optic Ports	21

RS-232 Port.....	21
DES-5024 to DES-5024 Connection.....	22
Connecting the DES-5024 to other Switches and Hubs.....	22
4	23
LEDs.....	23
CPU Module	24
12-Port 10/100-TX Module	26
2-Port 100BASE-FX Module	27
1-Port 1000BASE-SX Module	29
5	30
Managing the DES-5024.....	30
Local Console Management	31
Telnet.....	32
Log In	33
Help Message.....	34
Panel Conventions.....	35
Console Program.....	36
System Configuration	36
User Account Management	36
Switch Port 1-8, 9-16, 17-24 and Optional Module Configuration	36
100BASE-FX/ 1000BASE-SX Switch Port Module	37
Spanning Tree Configuration.....	37
SNMP Management Configuration.....	37
VLAN Port Management.....	37
Trunking Port Management	37
System Configuration Menu	38
System Information Menu	39
System Reset.....	41
Factory Reset.....	42
System Rate Control.....	44
Software Update Menu	46
User Account Management	49
User Account Change Menu.....	49

Create New User	50
Delete Users	52
Change Password	54
Switch Port Configuration	56
Switch Port Configuration Menu	57
Spanning Tree Configuration.....	59
STA Operation Levels	59
Spanning Tree Configuration Menu.....	59
SNMP Management Configuration.....	62
SNMP Management Configuration Menu.....	63
VLAN Port Management.....	66
VLAN Port Management Menu.....	67
Create New VLAN.....	68
Delete VLAN Menu	70
Trunking Port Management Menu	72
Create New Trunking Port.....	73
Delete Trunking Port.....	75
6	77
Troubleshooting	77
Appendix A	80
DES-5024 Technical Specifications	80
Switch Specifications	80
Port Specifications.....	80
Index.....	84

About This Guide

This section defines the scope of this guide and gives a summary of the contents of each chapter. It describes the features of the D-Link DES-5024 Fast Ethernet Switching System. Information about the DES-5024 and other D-Link products is available on our web site at www.dlink.com.

Audience

This user guide is intended for the networking or computer technician who is installing the DES-5024 on a network. Refer to other sources for information about networking in general.

All the information you need to install, configure and troubleshoot the DES-5024 is contained in this user guide.

Organization

Chapter 1, *Introduction*, gives a physical and functional overview of the DES-5024. The DES-5024 features, LEDs, and management methods are covered.

Chapter 2, *Installing the DES-5024*, covers installing and powering on the DES-5024.

Chapter 3, *Connecting the DES-5024 to the Network*, covers connecting the DES-5024 to the network, maximum cable length, cable specifications and connections between multiple DES-5024s.

Chapter 4, *LEDs*, covers reading and interpreting the LED panel.

Chapter 5, *Managing the DES-5024*, covers all the menus and configurations available.

Chapter 6, *Troubleshooting*, covers troubleshooting the DES-5024.

Appendix A, *DES-5024 Technical Specifications*, covers the technical specifications of the DES-5024.

Introduction

This chapter gives a physical and functional overview of the DES-5024. The DES-5024 is an intelligent, managed switch, designed for use on medium sized networks as part of the backbone or for use with other switches and hubs on a larger network.

There are two optional modules available: a 2-Port 100BASE-FX and 1-Port 1000BASE-SX gigabit module. The modules can only be installed in slot 3. Optional modules can be ordered at the time of purchase or later.

The chapter is divided into the following sections. Each section briefly describes the features of the DES-5024. Most of the topics discussed will be explained in greater detail later in the manual.

The topics covered are:

- Summary of Features
- Modules of the DES-5024
- Explanation of Front and Rear Panels
- Management Methods
- Updating Firmware

Features

The DES-5024 has the following features:

- All 24 TX ports auto-negotiate 10/100 Mbps.
- One half-size slot supporting two optional, installable modules, 2-Port 100BASE-FX, and 1-Port 1000BASE-SX module.
- The DES-5024 can be configured and customized to your network.
- The DES-5024 can be managed in three ways: Local Console Management, Telnet and SNMP.
- Supports Cut-through and Store-and-Forward switching.
- Supports Full and Half Duplex for both 10 Mbps and 100 Mbps.
- Eight thousand active MAC address table entries per device with self-learning and table aging.
- The DES-5024 supports SNMP for RFC 1213, RFC 1757, and RFC 1493.
- VLAN support for eight broadcast domains.
- Port Trunking support for bandwidth aggregation between two DES-5024 switches.

- Modular chassis that accepts RJ-45, fiber optic and gigabit expansion modules
- Support for RMON statistics through SNMP software.
- The 1000BASE-SX port supports flow control compliant with IEEE 802.3 standard.

Front Panel

The DES-5024 is designed for management at a glance. The front of the DES-5024, displayed in Figure 1, has LEDs that give you essential information at a glance.

The DES-5024 is a modular unit. The chassis has five slots. All the modules have LEDs. See Chapter 4, *LEDs*, for information on interpreting the LEDs. The slots are in the following order: CPU module is always on top. Slots one and two are full sized and come with two 12-Port 10/100-TX Modules. Slots three and four are half sized and only slot 3 can accommodate feature modules. Slot 4 may not be used.

All ports can be used for network connections. The RS-232 port is used for Out of Band Management.

All LEDs are located on the front panel of the DES-5024. Their purpose is to allow you to monitor the operation and performance of the DES-5024 at a glance.

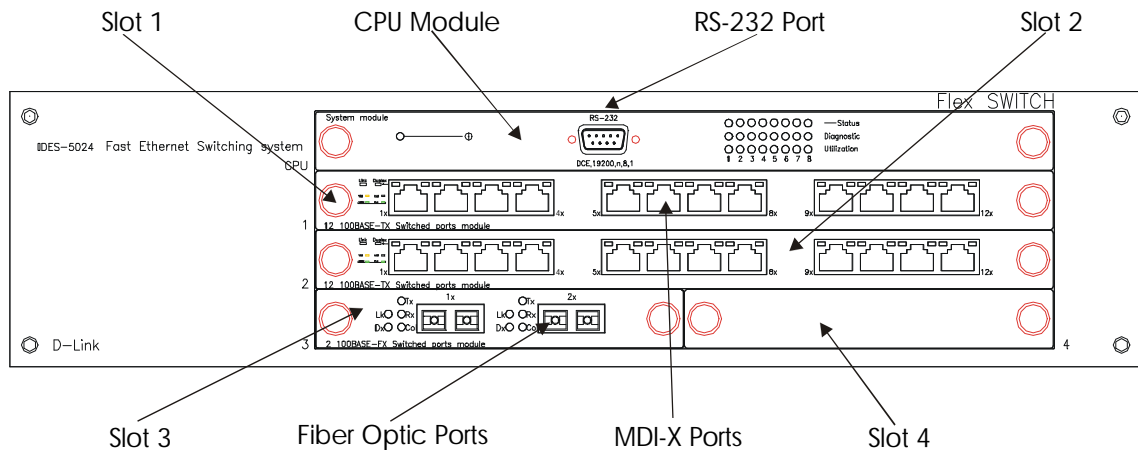

Figure 1: DES-5024 Front Panel

Rear Panel

The three pronged power plug, ventilation fan and the on/off switch are located at the rear of the DES-5024 displayed in Figure 2. The DES-5024 will work with AC in the range 100-240 VAC, 50-60 Hz. The power requirements are indicated on the rear panel of the DES-5024. When installing the DES-5024, leave enough room to allow you to plug in the power cable.

There are heat vents located on the sides. The fans and the vents help to cool the DES-5024. Always leave two inches of space around the DES-5024 so that air can circulate and cool the DES-5024.

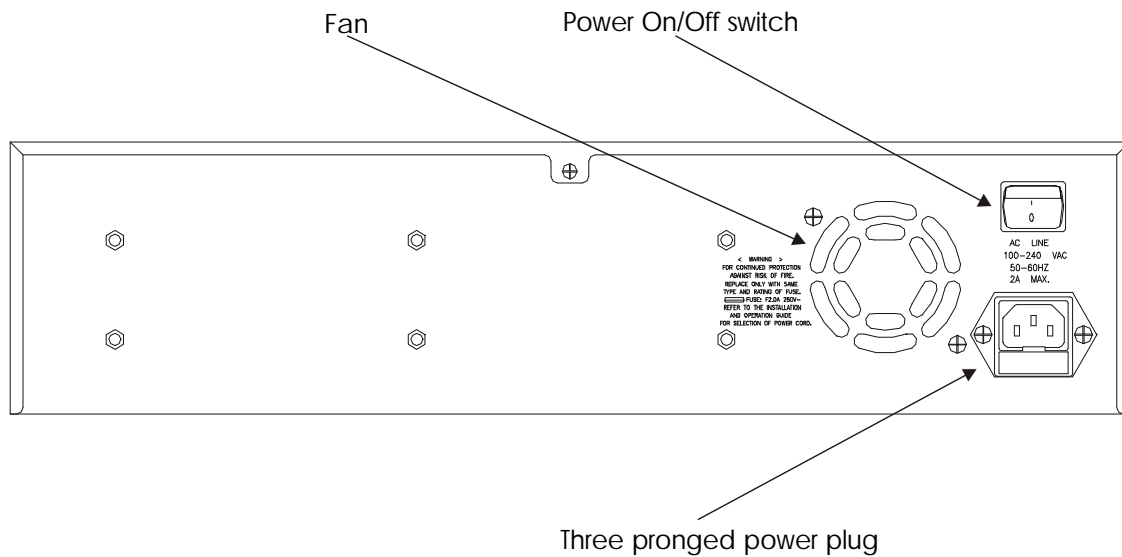

Figure 2: DES-5024 Rear Panel

Management Methods

The DES-5024 supports three management methods:

- Local Console Management
- Telnet Management
- D-View/ SNMP Management

Local Console Management

Local Console Management is done through the RS-232 Console port. Managing the DES-5024 in this mode requires a direct connection between a PC and the DES-5024.

Telnet Management

Telnet is done over the network. Once the DES-5024 is on the network, you can use Telnet to log in and change the configuration.

D-View/ SNMP Management

The DES-5024 supports SNMP through D-View, D-Link's proprietary SNMP application and through other vendors' SNMP applications. Please refer to the appropriate documentation for instructions on installing and using D-View and other SNMP applications.

RMON

The DES-5024 is an RMON agent. RMON statistics can be gathered through SNMP software. There is no option to gather RMON statistics without using SNMP software.

Updating Firmware

Firmware can be updated quickly and easily. See the section Software Update Menu, *Chapter 5*, for instructions on updating firmware.

Installing the DES-5024

This chapter covers the following:

- Unpacking the DES-5024
- Installation Options
- Installing Optional Modules
- Powering on the DES-5024

Unpacking the DES-5024

Open the box and carefully unpack the DES-5024. You should have all the items on the following checklist:

- DES-5024 Fast Ethernet Switching System
- RS-232 DCE serial cable
- Two mounting brackets and eight screws
- Four rubber pads with adhesive backing
- One six foot (1.82 m) power cord
- DES-5024 User's Guide CD ROM, DES-32/50 V.01 5.25/625M, part # 651DES32.K15.
- Registration Card

If any items are missing, contact the retailer where you purchased the DES-5024 for assistance.

Be sure to register the DES-5024 immediately. Failure to register the DES-5024 may void the warranty.

Installation Options

There are two options for installing the DES-5024: desktop/ shelf installation or rack installation.

Follow these guidelines for desktop/ shelf installation or rack installation:

- The surface must support 18 lbs or 8 kg.
- The power source must be within six feet (1.82 m)
- Power cord and cables should never be stretched
- Leave at least two inches (5.08 cm) around the DES-5024 for ventilation

The following tools and materials may be necessary to install the DES-5024:

- Screwdriver to install the brackets as needed
- Wire cutters to cut cable as needed for network connections
- Crimpers to crimp cable as needed
- RJ-45 connectors as needed
- SC fiber optic cable connectors

Refer to Chapter 3, Cable Specifications for cable types and specifications.

Desktop/ Shelf Installation

The dimensions of the DES-5024 are 17.362 inches (441 mm) x 10.393 inches (264 mm) x 4.645 inches (118 mm). These measurements include the 8-mm rubber feet provided with the DES-5024.

Follow these steps to install the DES-5024 on a desktop or shelf:

1. Place the four rubber feet at the corners of the DES-5024. See Figure 3 and Figure 4.
2. Place the DES-5024 on the desktop/shelf.

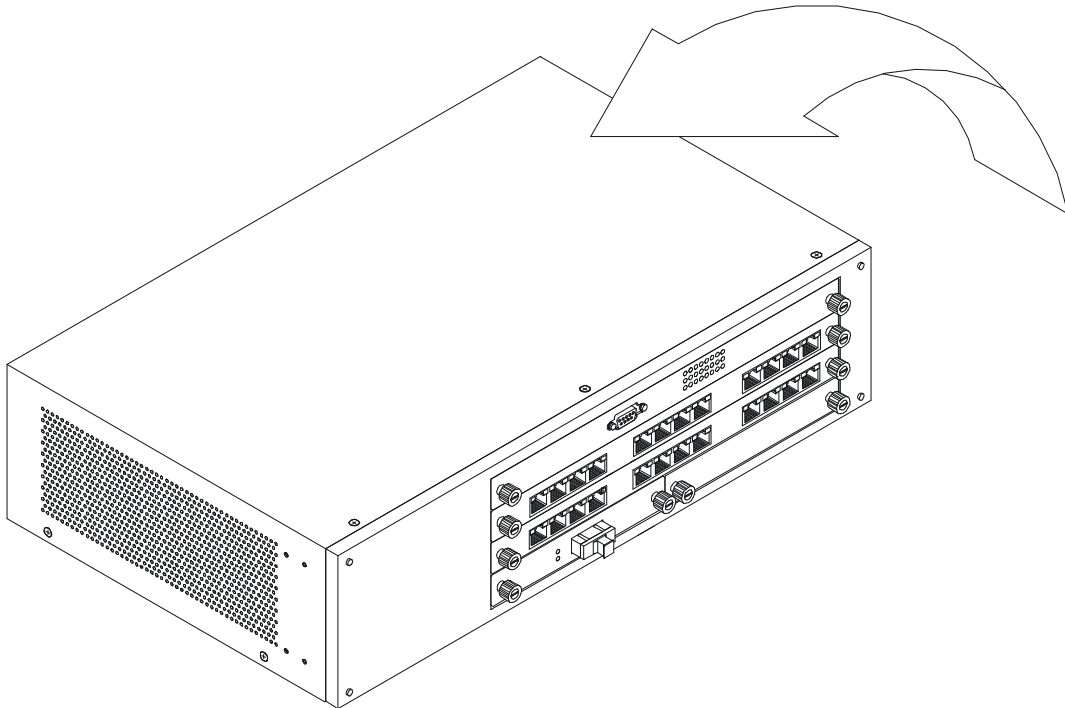

Figure 3: Install Feet on Bottom

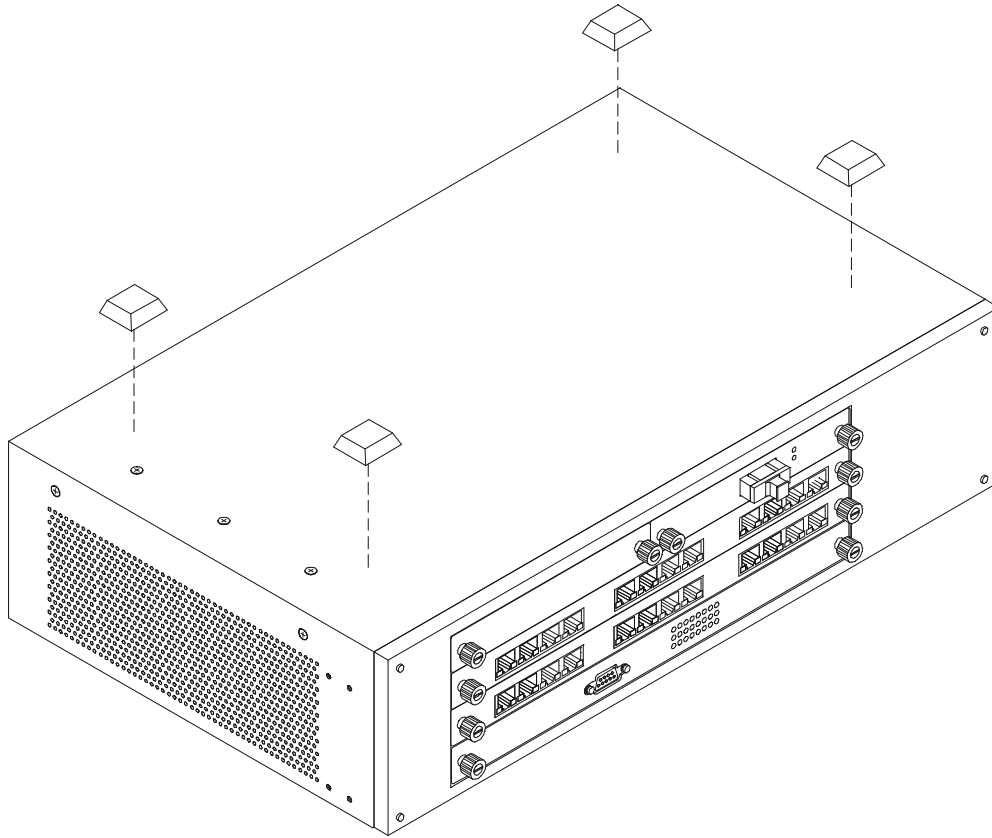

Figure 4: Attach Feet

Rack Installation

The DES-5024 can be mounted in an EIA standard size, 19-inch rack. The dimensions of the DES-5024 are 17.362 inches (441 mm) x 10.393 inches (264 mm) x 4.33 inches (110 mm). The DES-5024 can be placed in a wiring closet along with other equipment.

Follow these steps to install the DES-5024 on a rack:

1. Attach a mounting bracket to each side of the DES-5024 with the screws provided. See Figure 5.
2. Slide the DES-5024 into the rack and use the screws provided to secure the DES-5024 to the rack. See Figure 6.
3. Connect the power cord and verify that the DES-5024 is receiving adequate power.

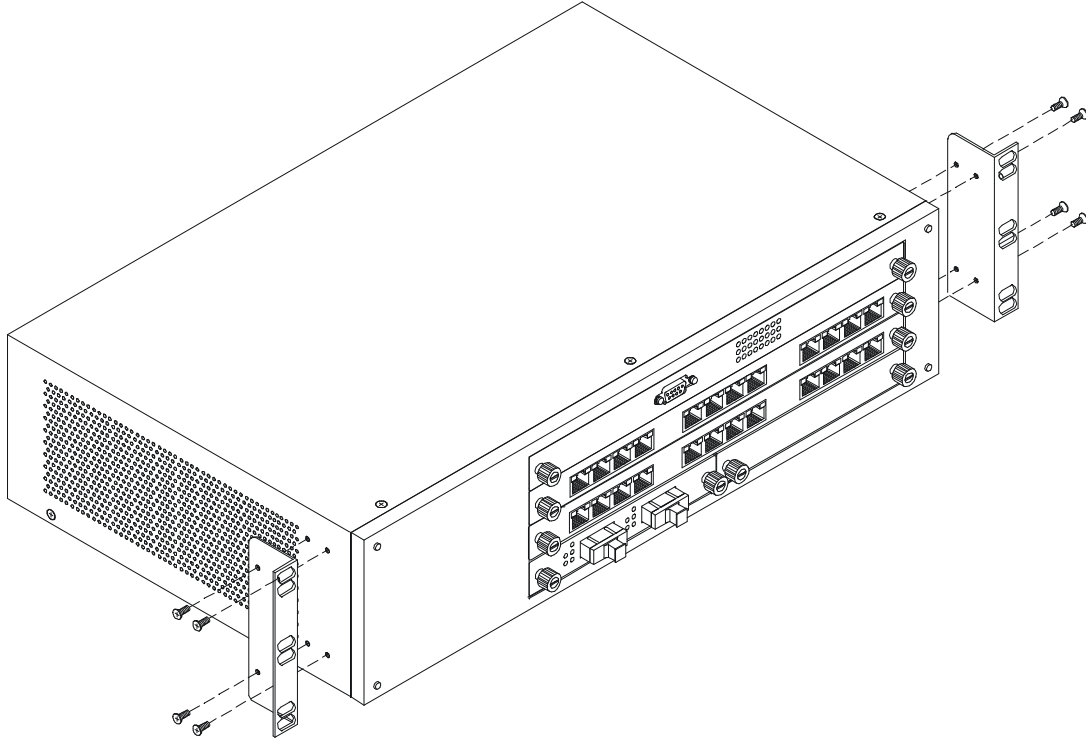

Figure 5: Attach Mounting Brackets

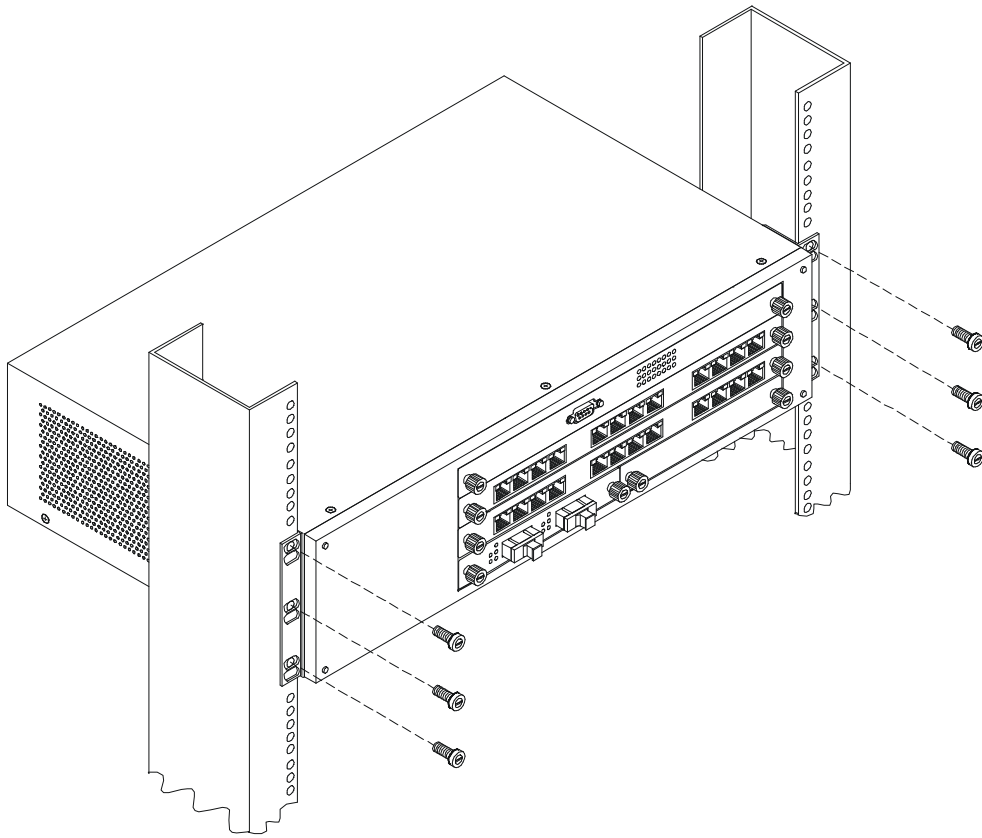

Figure 6: Insert into Rack

Installing Modules

The process for installing both optional modules is the same. You cannot change the position of the CPU module. The DES-5024 will not work unless the CPU module is installed in the CPU slot.

You can purchase optional modules separately in order to meet the needs of your network. The two optional modules available for the DES-5024 are: a 2-Port 100BASE-FX (fiber optic) module and a 1-Port 1000BASE-SX (gigabit) module. As shown in Figure 7, optional modules can only be installed in Slot 3. Nothing can be installed in slot 4. The procedure for installing modules is the same for all both modules.

Follow these steps to install an optional module:

1. Power the DES-5024 off before installing the optional module. The optional modules are not hot swappable.
2. Remove the blank bracket, as shown in Figure 7, and set aside. Grasp the thumbscrews on the sides of the blank bracket and turn counterclockwise to unscrew them. You can also use a Phillips screwdriver to unscrew the blank bracket. Do not discard the blank bracket. Put the blank bracket back in if you remove the optional module.
3. Install the optional module by inserting it into the guide, see Figure 8, and sliding it in until it stops. Press in firmly until you feel the optional module snap into place. The optional module should be level and flush with the rest of the DES-5024. Never force, twist or bend the module. The optional module slides in smoothly.
4. Gently push the thumbscrews in and turn clockwise to tighten. Do not over tighten the thumbscrews.
5. Power the DES-5024 on after you have installed the optional module. The DES-5024 will auto detect the optional module.
6. Remove the dust cover from the transceiver and plug the cable in.
7. Check the LEDs to verify that there is a link and a proper connection at the port.

See the Troubleshooting section if the optional module is not working properly.

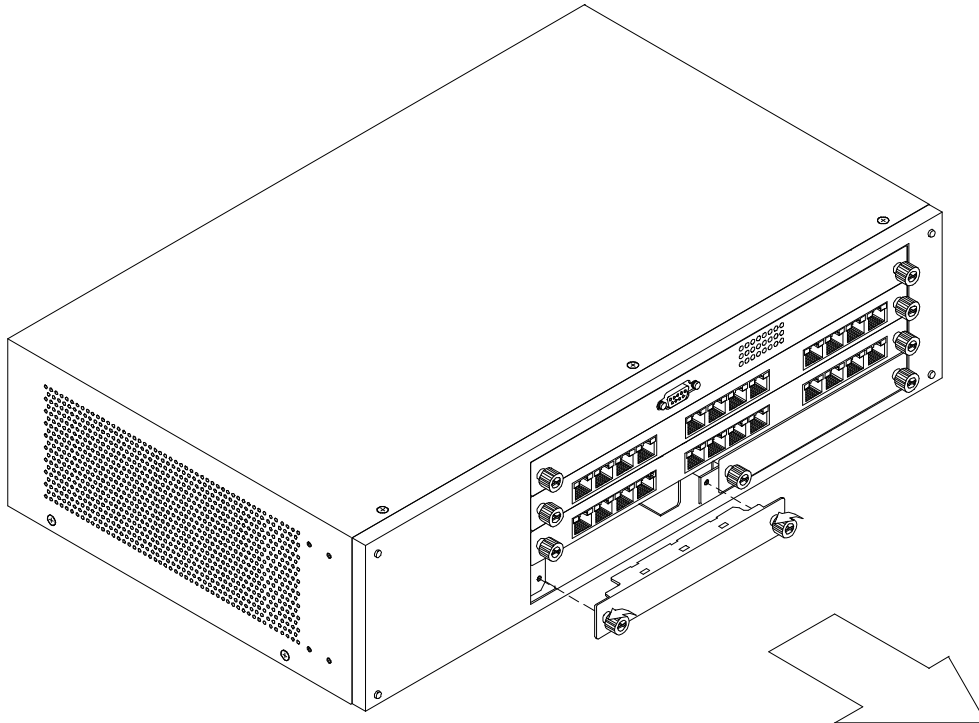

Figure 7: Remove Blank Bracket

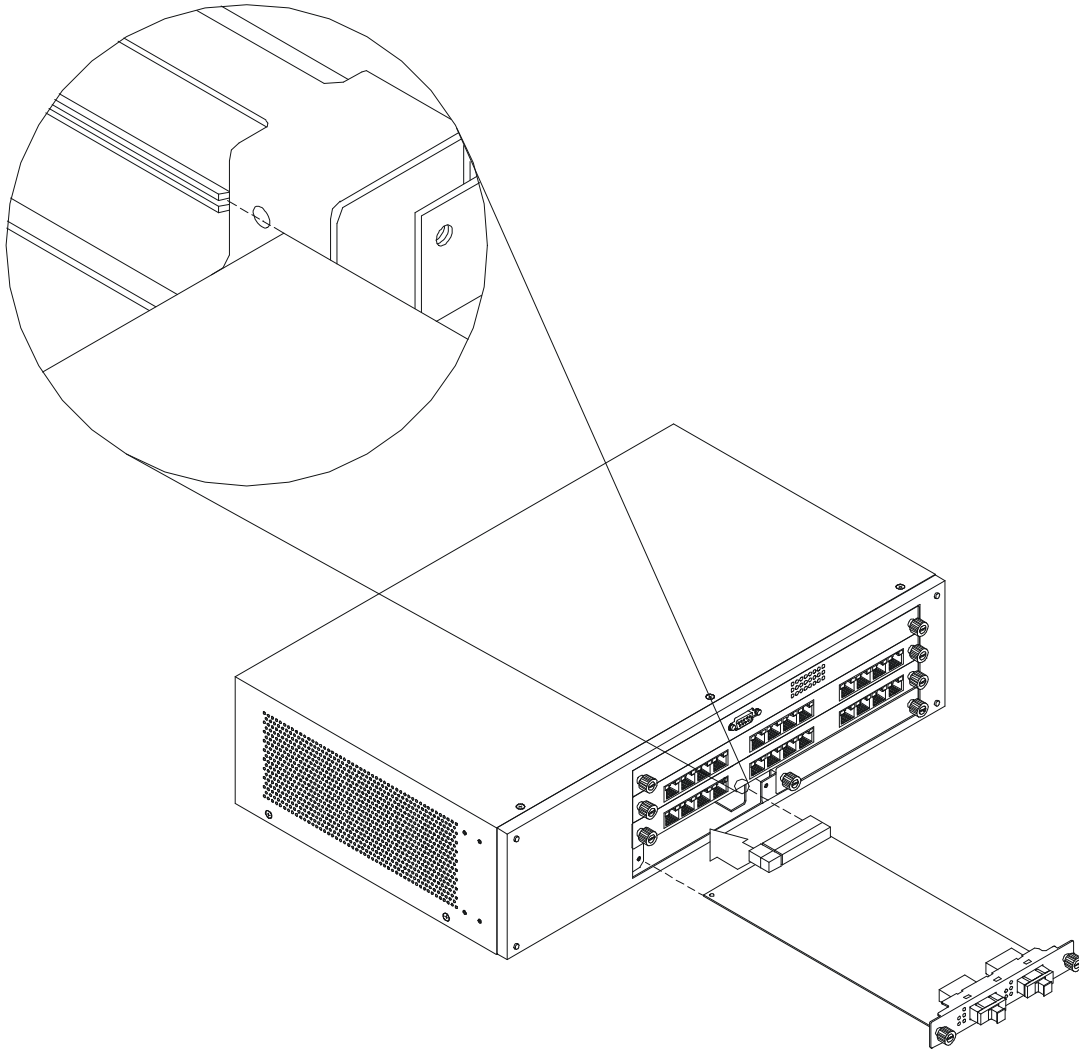

Figure 8: Insert Optional Module

Power On

The power supply will adjust to the local power source automatically. The DES-5024 may be plugged in without having any or with all LAN segment cables connected.

The power plug is located at the rear of the DES-5024. Plug the cable into the wall socket and plug the other end into the DES-5024. There is a power on/ off switch located at the rear of the DES-5024. Move the switch to the on position to power the DES-5024 on. The Power LED will light and all ports will auto negotiate the proper speed and duplex mode when the DES-5024 is powered on.

Reboot the DES-5024 if there is a problem. Contact D-Link Systems, Inc. for technical support.

Check the configuration of the DES-5024 after a power failure but do not reset unless it is necessary.

The DES-5024 can be used with power sources in the range 100 to 240 VAC., 50 to 60 Hz.

Connecting the DES-5024 to the Network

This chapter covers the following:

- Cable Specifications
- Ports
- Connecting the DES-5024 to another DES-5024
- Connecting the DES-5024 to other switches and hubs

This section deals with making cables and connecting the DES-5024 to other devices. It is extremely important that cables have the correct pin arrangement and that the proper cables be used when connecting to servers, switches, hubs, workstations and other devices.

Cable Specifications

Use the following guidelines when handling cables:

- Do not stretch or bend cables.
- Do not put copper cables near sources of electromagnetic interference. Fiber optic cables are immune to electromagnetic interference.
- Do not create trip hazards by laying cables in aisles and walkways.
- Secure cables to the floor when routing in aisles or walkways.

Do not use telephone cable. Telephone cable does not support Ethernet or Fast Ethernet.

Copper Cable

In order for Ethernet or Fast Ethernet to work the wires must be arranged correctly inside the RJ-45 connector. The most common problem on Ethernet or Fast Ethernet networks is the cable. If you migrate from Ethernet to Fast Ethernet, make sure the cables are pinned out properly.

There are two types of cables: straight through and crossover. Category 3, 4, or 5 UTP/STP cable has eight wires inside the sheath. The wires form four pairs. Straight through cable has the same pin out, inside the RJ-45 connector, at both ends. Crossover cable has a different pin arrangement at each end. Fast Ethernet does not tolerate incorrect pin arrangements. You must use the correct pin arrangement in order for the DES-5024 to work properly. See Figure 9 for an example of straight through and crossover cable.

The type of cable you use depends on the speed of your network. A network running at 10 Mbps can use lower grade cable than a network running at 100 Mbps., Table 1: Cable Specifications, shows the cable requirements for Ethernet and Fast Ethernet networks.

Table 1: Cable Specifications for Copper Connection

Ethernet Type	Cable Requirements	Maximum Length
10BASE-T	Category 3, 4, or 5 UTP or STP	328 ft (100 M)
100BASE-TX	Category 5 UTP or STP	328 ft (100 M)

568B Specification - Cable Fabrication Instructions

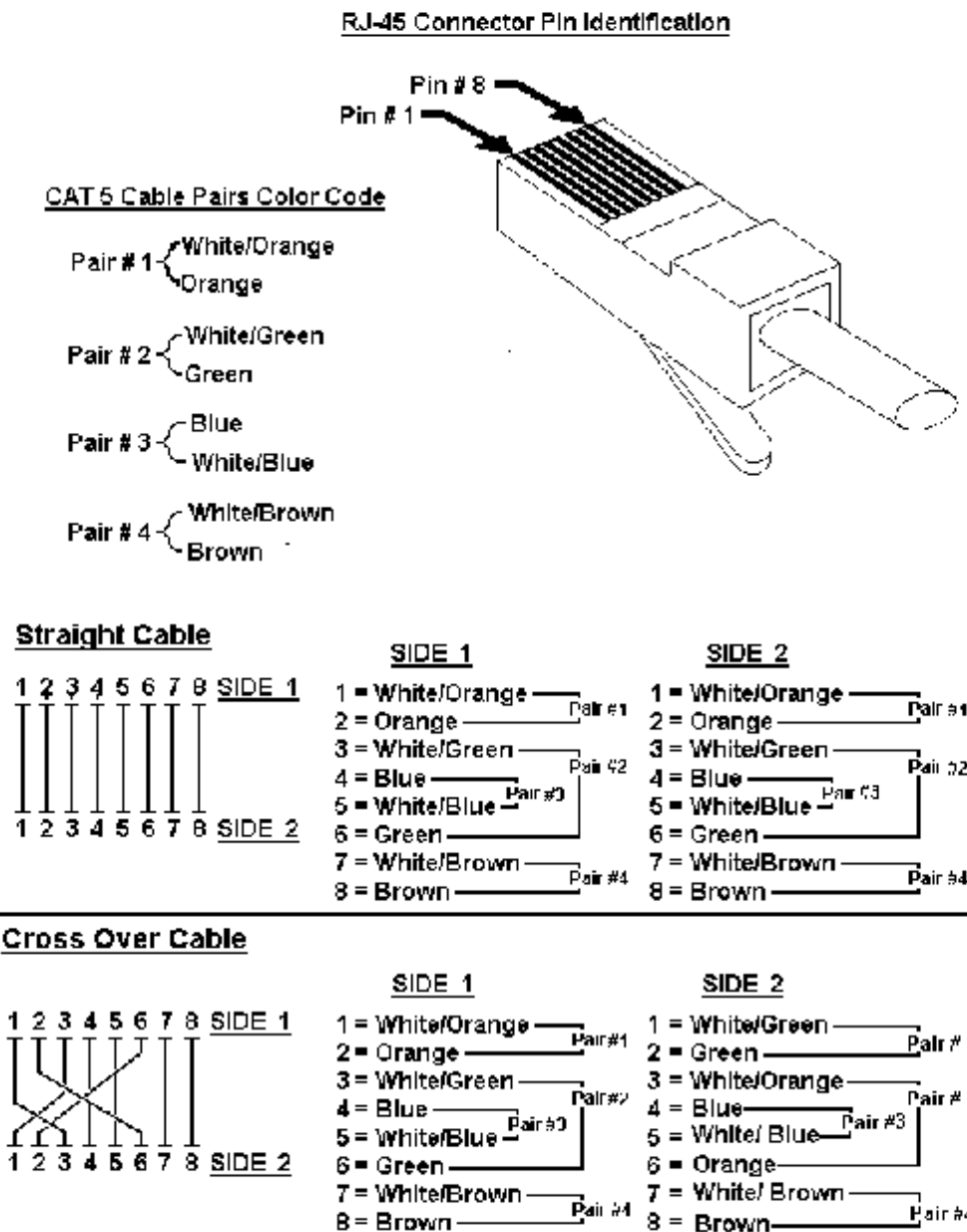

Figure 9: Cable Diagram

Fiber Optic Cable

Data can travel much farther over fiber optic cable than over Category 3, 4 or 5 cable. Cable length can be up to 1.25 miles (two kilometers) in full duplex and 1350 feet (412 meters) in half duplex transmitting at 100 Mbps.

Fiber optic cables connected to the fiber expansion module for 100 Mbps must meet the following specifications to carry 1300 nm wavelength for the specified distance:

- Multi-mode cable ISO/IEC 793-2 type B1 and ITU-T G.652 standards
- Cable must have SC connectors

Fiber optic cables attached to the gigabit expansion module must meet the following specifications to carry 850 nm wavelength for the specified distance:

- Multi-mode cable ISO/IEC 793-2 type B1 and ITU-T G.652 standards
- Cable must have SC connectors

Gigabit traffic can travel the following distances using the specified cable:

- 62.5 um cable 720 feet (220 meters)
- 50 um cables 1639 feet (500 meters)

Ports

MDI-X Ports

MDI-X ports are crossover ports. The pin arrangement is the same as the arrangement in a crossover cable. The advantage of MDI-X ports is that you can connect a device with an MDI-II port without using a crossover cable. The steps for connecting the DES-5024 to 10 Mbps devices or 100 Mbps devices are the same. All the ports will auto negotiate the proper speed and duplex mode. The DES-5024 has two full sized modules with 12 ports each and one half size optional module.

Follow these steps to connect cables to the DES-5024:

Check for the appropriate cable configuration for each device.

1. Plug one end of the cable into any of the MDI-X ports.
2. Plug the other end into the appropriate port on the other device.
3. Verify that the LED indicates connection at the proper speed and duplex mode.

Fiber Optic Ports

The DES-5024 supports 100BASE-FX and 1000BASE-SX. The ports are on modules that you can install in the chassis. The chassis supports a 2-Port 100BASE-FX optional module. The ports support full and half duplex at 100 Mbps. The ports do not support 10 Mbps.

A 1-Port 1000BASE-SX optional module is available. The 1-Port 1000BASE-SX optional module only supports full duplex at 1000 Mbps. Contact D-Link, Inc. sales to purchase any of the modules.

Refer to Chapter 3, *Installing Optional Modules*, for installation instructions. Refer to Chapter 3, *Cable Specifications*, for information on cable types and connectors.

RS-232 Port

Follow these steps to connect the DES-5024 and another device:

1. Plug one end of the cable provided into the port.
2. Plug the other end into the PC.
3. Run HyperTerminal or a terminal emulation program using the settings given for Local Console Management at the beginning of Chapter 5, *Managing the DES-5024*.

DES-5024 to DES-5024 Connection

Connect two DES-5024s together through one or more MDI-X ports. See the section on Port Trunking in Chapter 5 for instructions on how to configure trunked ports.

Connecting the DES-5024 to other Switches and Hubs

You can connect the DES-5024 to other switches and hubs on the network. The DES-5024 is compatible with the DES-5016, DES-3216 and DES-3224. Port trunking can be configured on the device if more than one port is connected between a DES-5024, DES-5016, DES-3216 and DES-3224. Port trunking increases the efficiency of the DES-5024 by increasing the bandwidth. See the section on Port Trunking in Chapter 5 for instructions on how to configure trunked ports.

LEDs

The LED panel of the DES-5024, is designed to allow you to manage the DES-5024 at a glance. The LEDs indicate the following:

- Power
- Status
- Diagnostic
- Utilization
- Link
- Speed
- Duplex mode
- Collision
- Receiving
- Transmitting

All LEDs are described in detail, see Figure 10. Use the tables to determine the meaning of each LED.

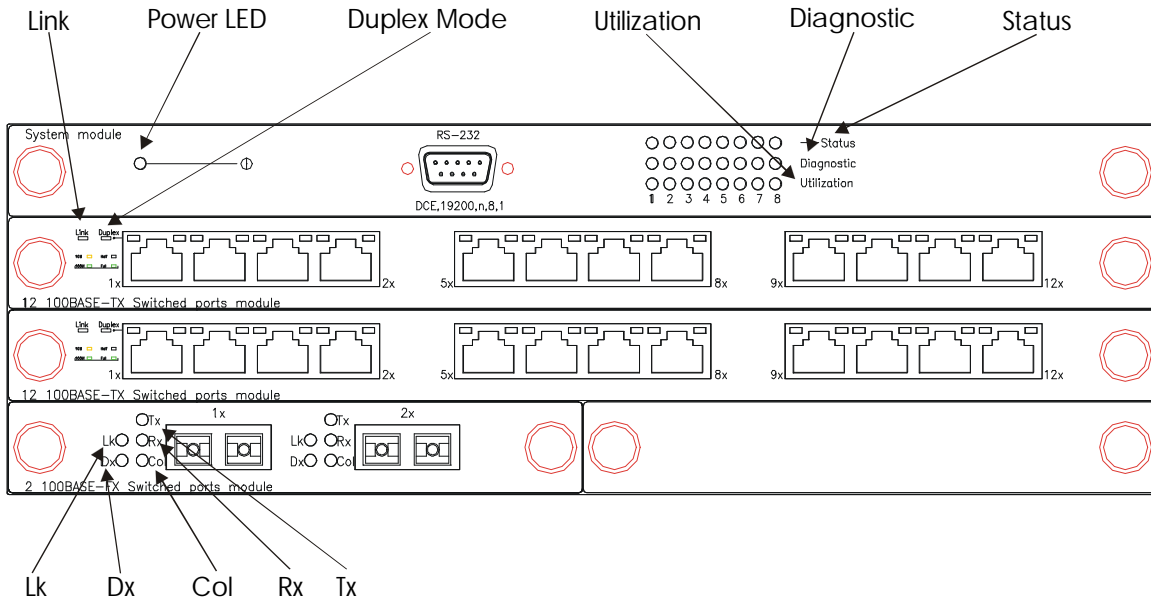

Figure 10: DES-5024 LEDs

CPU Module

The CPU module, displayed in Figure 11, is at the top of the chassis. This is the only slot it will work in. If it is not at the top of the chassis, the DES-5024 will not work. See Table 2: Power LED, for an explanation of the Power LED. See Table 3: CPU Module LED for an explanation of the LEDs on the CPU module.

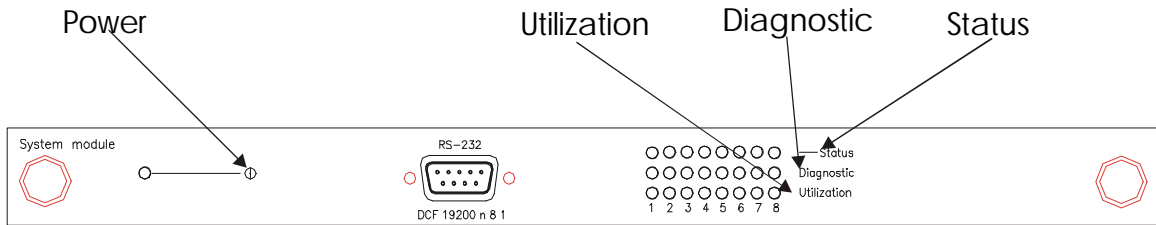

Figure 11: CPU Module

The meaning of the Power LED is displayed in Table 2: Power LED. The meaning of the remaining LEDs is displayed in Table 3: CPU Module LED.

Power

The power LED lights when the DES-5024 is powered on. The purpose is to confirm that the DES-5024 is getting adequate power.

Table 2: Power LED

Status	Color	Meaning
On	Green	DES-5024 is powered on
Off	Dark	DES-5024 is powered off, check power cable and connection

Status

The Status LED indicates the status of a firmware download. The LED will increment from left to right while firmware is being downloaded. It will be dark during normal operation.

Diagnostic

The Diagnostic LED is used to diagnose any problem on the DES-5024. If any part of the DES-5024 fails the POST or if a problem occurs the Diagnostic LED displays a code indicating the problem. See Chapter 6 for the meaning of the LED code and a recommended action.

Utilization

The Utilization LED indicates the utilization of the DES-5024's CPU. It increments from left to right. The higher the number the greater the utilization.

Table 3: CPU Module LED

LED	Color	Dark
Status	Status LED increments when firmware is being loaded to the DES-5024	Normal if firmware is not being loaded
Diagnostic	Displays the error codes if there is a failure during the POST or during operation	Normal if there are no problems. See Chapter 6 for a chart showing the meaning of the Diagnostic LED.
Utilization	Displays the utilization of the DES-5024. LED increments left to right, higher numbers indicate greater utilization.	Check Diagnostic if DES-5024 is on and all utilization LED are dark

12-Port 10/100-TX Module

The LEDs on the 12-Port 10/100-TX Module is displayed in Figure 12. The meaning of the LEDs is displayed in Table 4: 12-Port 10/100-TX Module LEDs.

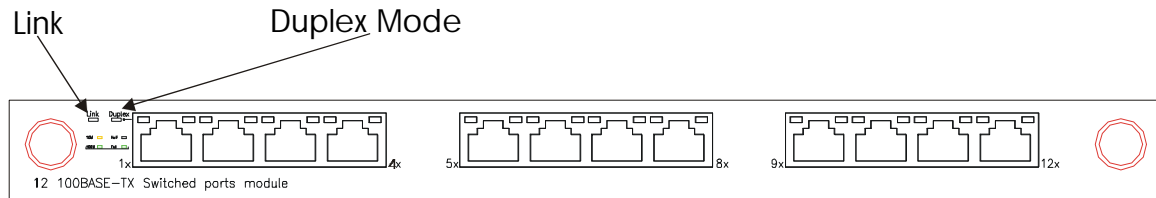

Figure 12: 12-Port 10/100-TX Module LEDs

Link

The Link LED indicates there is a link at the port. If a cable is plugged into the port and the Link LED is off, check the cable and connection. The default value is that all ports auto-negotiate the proper speed and duplex mode. If the port has been manually configured for a particular speed and duplex mode, verify that the speed and duplex mode of the port match the speed and duplex mode of the device you are connecting to.

The color of the Link LED indicates the port's speed. Orange indicates the port is operating at 10 Mbps. Green indicates the port is operating at 100 Mbps.

Duplex

The Duplex LED indicates the duplex mode the port is in. All 24 ports, and the expansion modules, auto-negotiate the duplex mode by default. Each port can be manually set for a particular speed and duplex mode. Off indicates the port is in half duplex mode. Green indicates the port is in full duplex mode. Full duplex means the port is transmitting and receiving data simultaneously. Half duplex means that data is only being transmitted or received in one direction at a time.

Table 4: 12-Port 10/100-TX Module LEDs

LED	Color	Dark
Link	Orange indicates port speed is 10 Mbps Green indicates port speed is 100 Mbps	No link or link is down
Duplex	Port is working at full duplex	Port is working at half duplex

2-Port 100BASE-FX Module

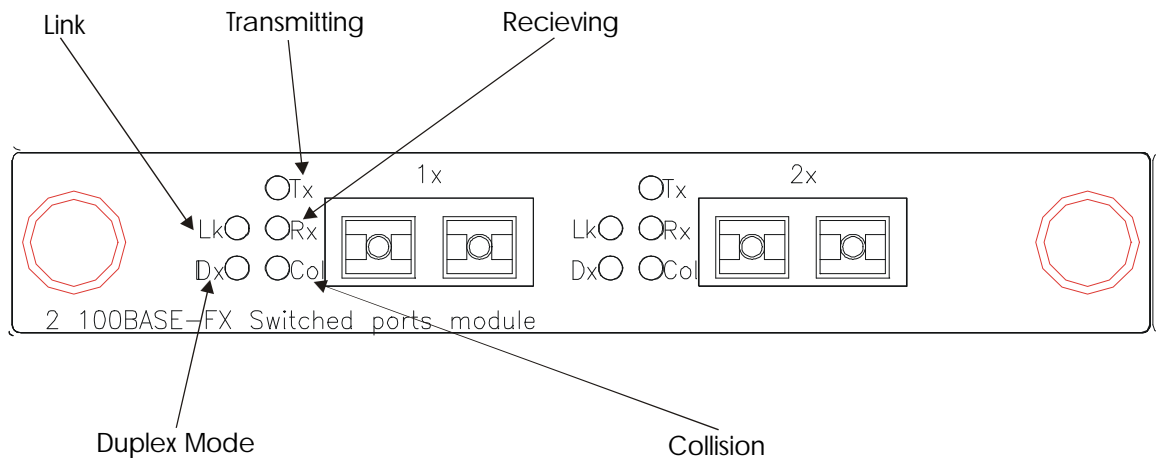

Figure 13: 2-Port 100BASE-FX Module

The LEDs on the 2-Port 100BASE-FX module, displayed in Figure 13, are different from the LEDs on the other modules. The information given is the same but it is presented differently.

Lk

Lk means link. The Lk LED lights to indicate there is a link at the port.

Dx

Dx means duplex mode. The Dx LED indicates the port's duplex mode. The LED is lit when the port is in full duplex and dark when the port is in half duplex. The default mode is half duplex. The ports can be manually set for full duplex. They do not auto negotiate duplex mode.

Tx

Tx means transmitting. The Tx LED lights to indicate the port is transmitting data.

Rx

Rx means receiving. The Rx LED flashes when the port is receiving data.

Col

Col means collision. The Col LED lights amber when collisions occur at the port. Collisions are normal on the network. You should only be concerned when a high number of collisions happen at the port.

Table 5: FX Module LED

LED	Lit	Dark
Lk (Link) (Green)	Port is linked to another device	No link
Dx (Duplex mode) (Green)	Port is in full duplex	Port is in half duplex
Tx (Transmitting) (Green)	Port is transmitting data	No data is being transmitted
Rx (Receiving) (Green)	Data is being received	No data is being received
Col (collisions) (Amber)	Collisions are occurring at the port	No collisions are occurring

1-Port 1000BASE-SX Module

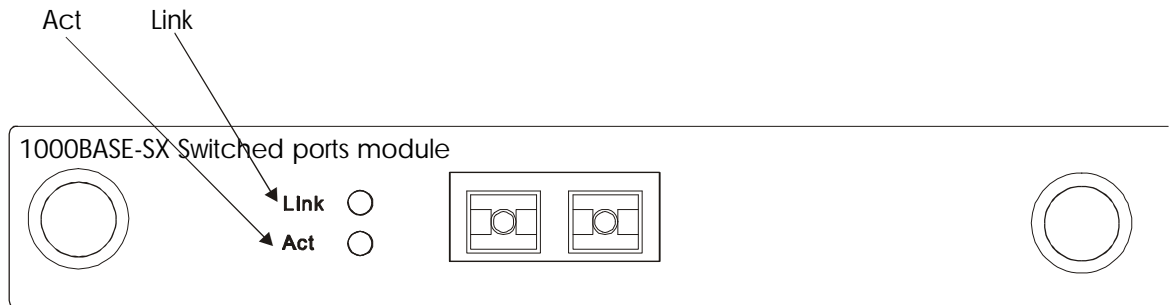

Figure 14: 1-Port 1000BASE-SX Module

The gigabit expansion module, displayed in Figure 14, has one port.

Link

The link LED lights to indicate there is a link at the port.

Act

Act means activity. The Activity LED indicates the port is transmitting or receiving data.

Table 6: Gigabit Module LED

LED	Lit	Dark
Link (Green)	Port is linked to another device	No link
Act (Yellow)	Port is transmitting or receiving data	Port is not transmitting or receiving data

Managing the DES-5024

This chapter shows the menus used to manage the DES-5024.

Three types of management are available on the DES-5024:

- Local Console Management (out-of-band)
- Telnet Management (in-band)
- D-View/ SNMP Management

The DES-5024 can be managed in-band or out-of-band. In-band management refers to managing the DES-5024 through one of the MDI-X ports.

Out-of-band management means going through the RS-232 port.

The interface and options are the same with Local Console and Telnet Management. The difference is the type of connection and the port that is used to manage the DES-5024.

D-View is a proprietary SNMP management program. D-View is provided with the DES-5024. The DES-5024 supports other SNMP management applications and uses standard MIB. Refer to appropriate documentation for installing and using other SNMP application programs. The look and feel of D-View is different from other management types. Refer to other documentation if you are using other vendors' SNMP applications.

All instructions given in this chapter assume that you are logged into the DES-5024 and are at the appropriate panel for carrying them out.

Local Console Management

Local Console Management is always done through the RS-232 serial port and requires a direct connection between the DES-5024 and a PC. This type of management is very useful when the network is down and the DES-5024 cannot be reached by any other means.

Use Local Console Management to log into the DES-5024 for the first time. You do not need to know the IP address to log into the DES-5024 using Local Console Management. You can change all the settings and configure the DES-5024, set the IP address and perform other management functions. The management session will timeout after five minutes if you have not taken any action. Press enter a few times to refresh the screen. You will have to log in again after a timeout.

Follow these steps to begin a management session using Local Console Management:

1. Attach the male end of the RS-232 serial cable provided with the DES-5024 to the RS-232 port located at the front of the DES-5024.
2. Attach the other end to the serial port of a PC or workstation.
3. Run a terminal emulation program using the following settings:
 - **Emulation:** VT-100/ANSI compatible
 - **BPS:** 19 200
 - **Data bits:** 8
 - **Parity:** None
 - **Stop bits:** 1
 - **Flow Control:** None
 - **Enable:** Terminal keys
4. Press Enter to display the login panel.
5. Log in using the default User Name and Password. The User Name and Password are case sensitive.
 - **User Name:** D-Link
 - **Default Password:** D-Link
5. Press Enter to reach the Main menu.

Telnet

You can manage the DES-5024 via Telnet session. However, first you must assign a unique IP address to the DES-5024. Use Local Console Management to log into the DES-5024 for the first time so that you can assign an IP address. Once you have assigned an IP address to the DES-5024, you can use the management method of your choice.

Telnet management can be done through any of the ports.

Follow these steps to manage the DES-5024 through a Telnet session:

1. Assign an IP address to the DES-5024.
2. Run Telnet.
3. Log into the DES-5024.

Log In

The Log In panel, displayed in Figure 15, is the first panel you see when connecting to the DES-5024. All management methods require you to log into the DES-5024 with your user name and password before beginning a management session. For security, you should change the default User Name and Password.

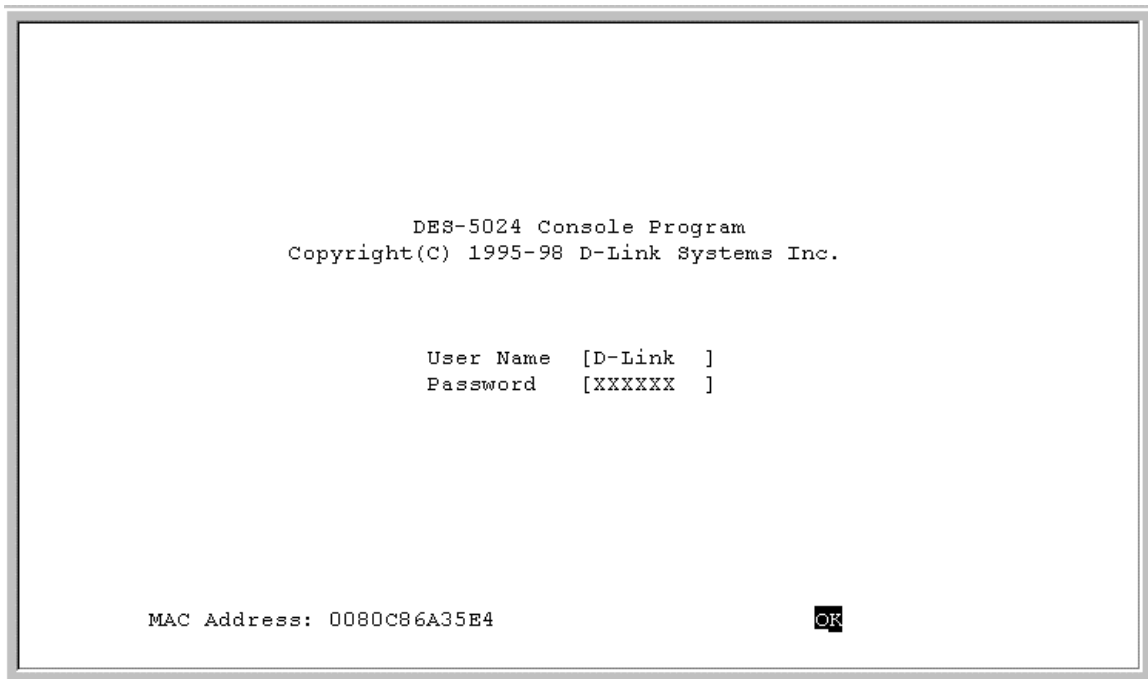

Figure 15: Login

Follow these steps to log into the DES-5024 for the first time:

Enter the default User Name and Password and press Enter. The User Name and Password are case sensitive.

- **Default User Name:** D-Link
- **Default Password:** D-Link

The MAC Address at the bottom of the screen cannot be changed.

Help Message

A one page panel, displayed in Figure 16, is available. The menu lists the keystroke and typographic conventions available on the DES-5024.

```
DES-5024 - Help Message

Please read the following menu operation guide:
Keystroke Conventions
Example      Description
UP, DOWN, or TAB keys  Select different items.
SPACEBAR     Toggle-switch.
DEL, or BACKSPACE     Remove any input character from the screen.
LEFT or RIGHT keys    Move cursor backward or forward.
Ctrl-r       Refresh Screen

Typographic Conventions
Example      Description
:168.8.254.20  Each read only value follows a colon.
<Enable>     Each changeable value can be changed only
              by the toggle switch.
[168.8.254.1] Each changeable value is enclosed in square
              bracket.
EXIT         Uppercase letters indicates COMMAND item.
Blinking Text Warning Message.

Press ENTER to Continue...
```

Figure 16: Help Message

Panel Conventions

Keystroke Conventions

Example	Description
UP, DOWN, or TAB keys	Select different items.
SPACEBAR	Toggle-switch.
DEL, or BACKSPACE	Remove any input character from the screen.
LEFT or RIGHT keys	Move cursor backward or forward.
Ctrl-r	Refresh Screen

Typographic Conventions

Example	Description
:168.8.254.20	Each read only value follows a colon.
<Enable>	Each changeable value can be changed only by the toggle switch.
[168.8.254.1]	Each changeable value is enclosed in square brackets.
EXIT	Uppercase letters indicate a COMMAND item.
Blinking Text	Warning Message.

After you are finished viewing the help panel, press Enter to return to the main menu.

Console Program

The Console Program, shown in Figure 17, is the main menu of the DES-5024.

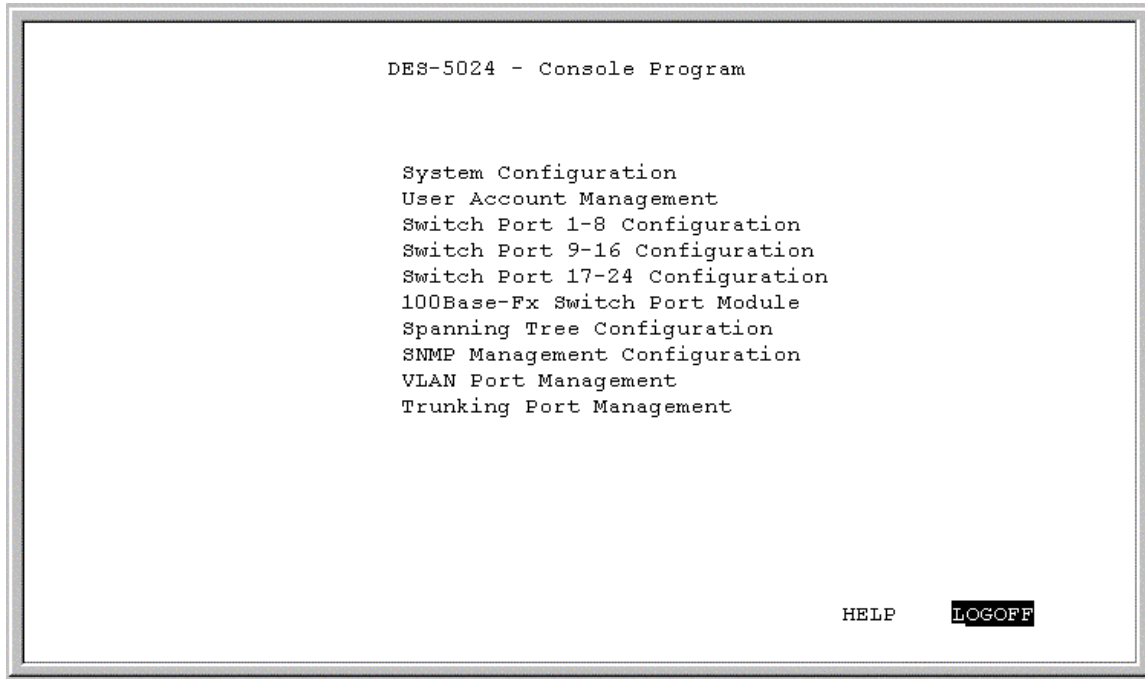

Figure 17: Console Program

System Configuration

The System Configuration menu gives you general information about the DES-5024 and allows you to assign a LAN IP Address, Subnet Mask, LAN Default Gateway and contact information on the system administrator.

User Account Management

The User Account Management menu allows you to add users, delete users and modify user account information.

Switch Port 1-8, 9-16, 17-24 and Optional Module Configuration

Switch Port 1-8, 9-16 and 17-24 Configuration allows you to configure individual ports. You can set the speed, duplex mode, enable and disable ports and make other changes.

To configure the optional modules, highlight them on the menu and select the appropriate module. The 2-Port 100BASE-FX and 1-Port 1000BASE-FX modules do not allow you to change the speed of the port.

100BASE-FX/ 1000BASE-SX Switch Port Module

Allows you to configure the ports on the expansion module. You can set the duplex mode, for the 100BASE-FX module, and enable and disable ports.

Spanning Tree Configuration

The Spanning Tree Configuration menu allows you to enable or disable Spanning Tree Algorithm, set the Bridge Priority, Hello Time, Forward Delay Time and the Max Age Time.

SNMP Management Configuration

The SNMP Management Configuration menu allows you to create SNMP Communities and configure SNMP Trap Manager Settings.

VLAN Port Management

The VLAN Port Management menu allows you to create, delete and modify VLANs quickly and easily.

Trunking Port Management

The Trunking Port Management menu allows you to create, delete and modify Trunking Ports quickly and easily.

Follow these steps to select a menu:

1. Use the tab key or the up and down arrow keys to select an option.
2. Press Enter.

System Configuration Menu

The System Configuration menu, displayed in Figure 18, allows you to change the configuration of the DES-5024.

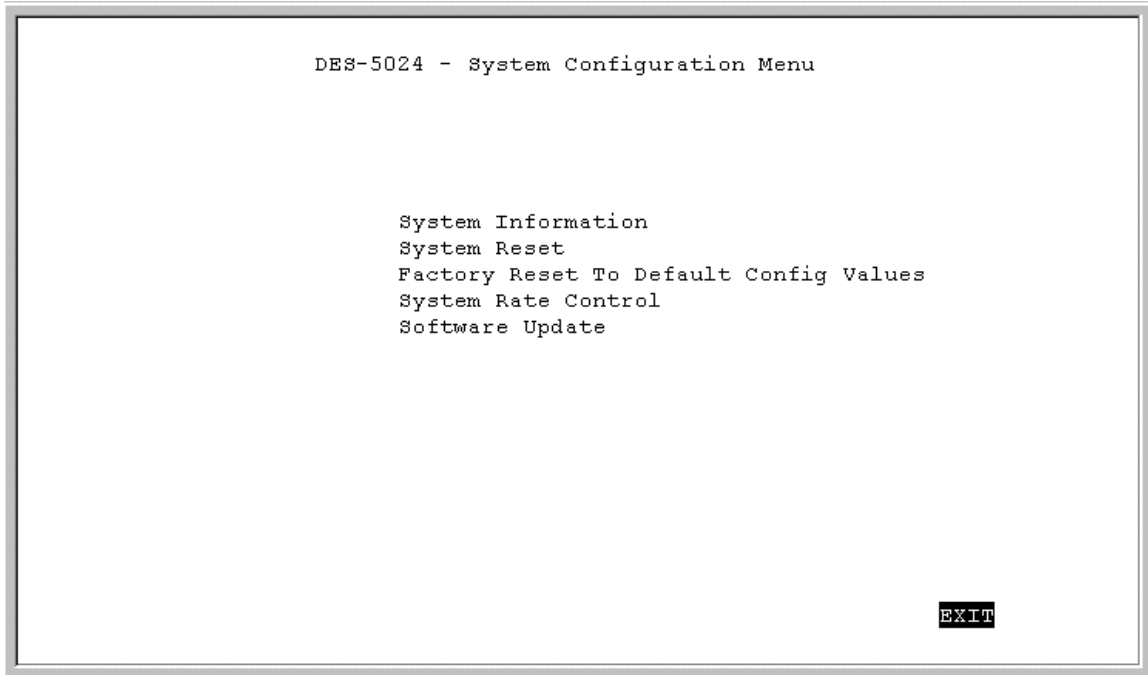

Figure 18: System Configuration menu

System Information

The System Information menu displays the Hardware revision, MAC address, LAN IP address and other information on the DES-5024.

System Reset

The System Reset menu allows you to reset the DES-5024 through software rather than powering off.

Factory Reset to Default Config Values

The Factory Reset to Default Config Values menu allows you to reload factory default configurations.

System Rate Control

The System Rate Control menu allows you to choose Store & Forward or Cut-Through. The advantages and disadvantages of each are explained in a later section.

Software Update

The Software Update menu is used to update the software on the DES-5024. This feature is only supported through Local Console Management.

Follow these steps to select a menu:

1. Highlight the menu option.
2. Press Enter.

System Information Menu

The System Information menu, displayed in Figure 19, allows you to enter management and configuration information on the DES-5024.

```
DES-5024 - System Information Menu

Hardware Revision:          Rev. A1
Boot PROM Firmware Version: V2.15
Software Version:          V2.15
MAC Address:                0080C86A35E4

System Description:
  10/100 Fast Ethernet Switching Hub
System Name                 [DES-5024 Ethernet Switching Hub      ]
System Location             [53 Discovery, Irvine, CA 92618, USA   ]
System Contact              [D-Link Systems Inc., (949) 788-0805   ]
LAN IP Address              [168.8.53.228          ]
LAN Subnet Mask             [255.255.0.0          ]
LAN Default Gateway         [0.0.0.0              ]

                               SAVE      EXIT
```

Figure 19: System Information

Hardware Revision

Specifies the hardware revision and the product generation. Each revision is numbered incrementally.

Boot PROM Firmware Version

Specifies the version of the Boot PROM being used on the DES-5024. Each version is numbered incrementally.

Software Version

Specifies the software version being used on the DES-5024. You can update the software. Each version is numbered incrementally.

MAC Address

Specifies the hardwired address of the DES-5024. This address cannot be changed.

System Description

Brief manufacturer description of the DES-5024. This value cannot be changed.

System Name

Specifies the full name of the DES-5024. This value can be changed, allowing you to assign a unique name to the DES-5024. You can enter up to 44 characters.

System Location

Specifies the physical location of the DES-5024, such as a building number or street address. You can enter up to 44 characters.

System Contact

Specifies the contact information of the network administrator. You can enter up to 44 characters.

LAN IP Address

Specifies the unique IP address of your LAN. You can enter up to 15 characters.

LAN Subnet Mask

Specifies the subnet mask, if you are subnetting. If you are not subnetting leave the default in place. You can enter up to 15 characters.

LAN Default Gateway

Specifies the default gateway. You can enter up to 15 characters.

Follow these steps to enter user changeable information:

Select the field you would like to edit.

1. Delete the default information
2. Enter the new information.
3. Select Save and press Enter. Follow screen prompts.

System Reset

The System Reset panel, displayed in Figure 20, enables you to reset the DES-5024 without powering off.

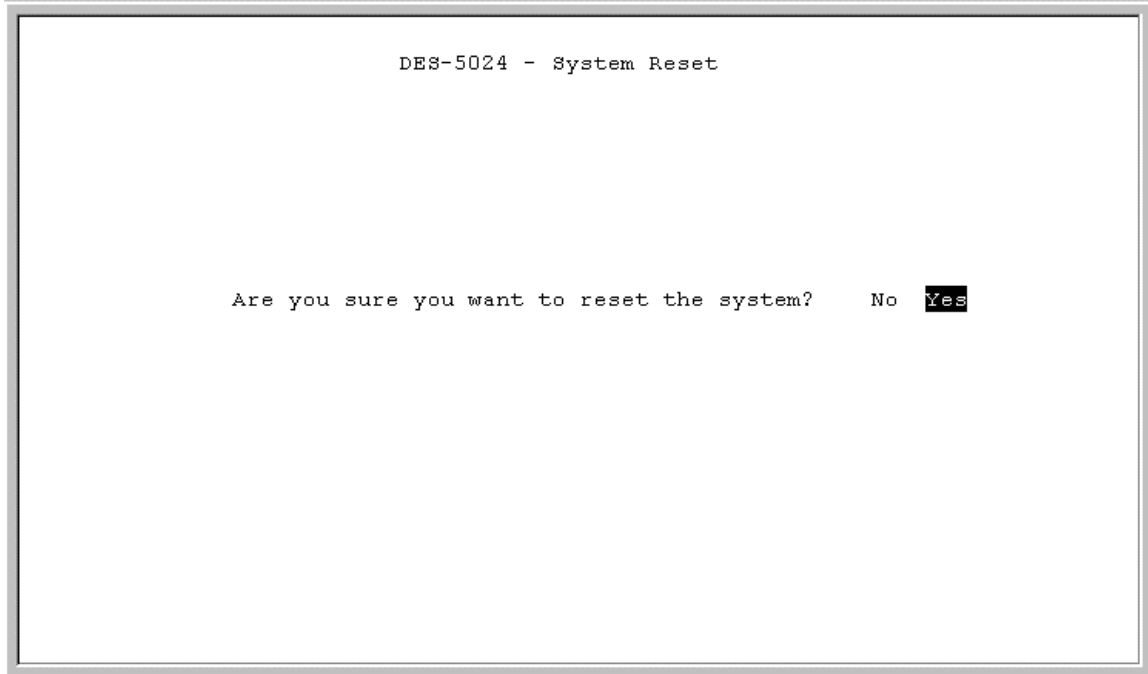

Figure 20: System Reset

Some configurations will require you to reset the DES-5024 in order for them to take effect. Screen prompts will tell you to reset the DES-5024 as needed.

Follow these steps to reset the DES-5024:

1. Select Yes.
2. Press Enter.

To exit without resetting:

1. Select No.
2. Press Enter.

Factory Reset

The Factory Reset panel, displayed in Figure 21, is used to reset the DES-5024 and restore all factory default values. Using this panel erases all configurations and customization.

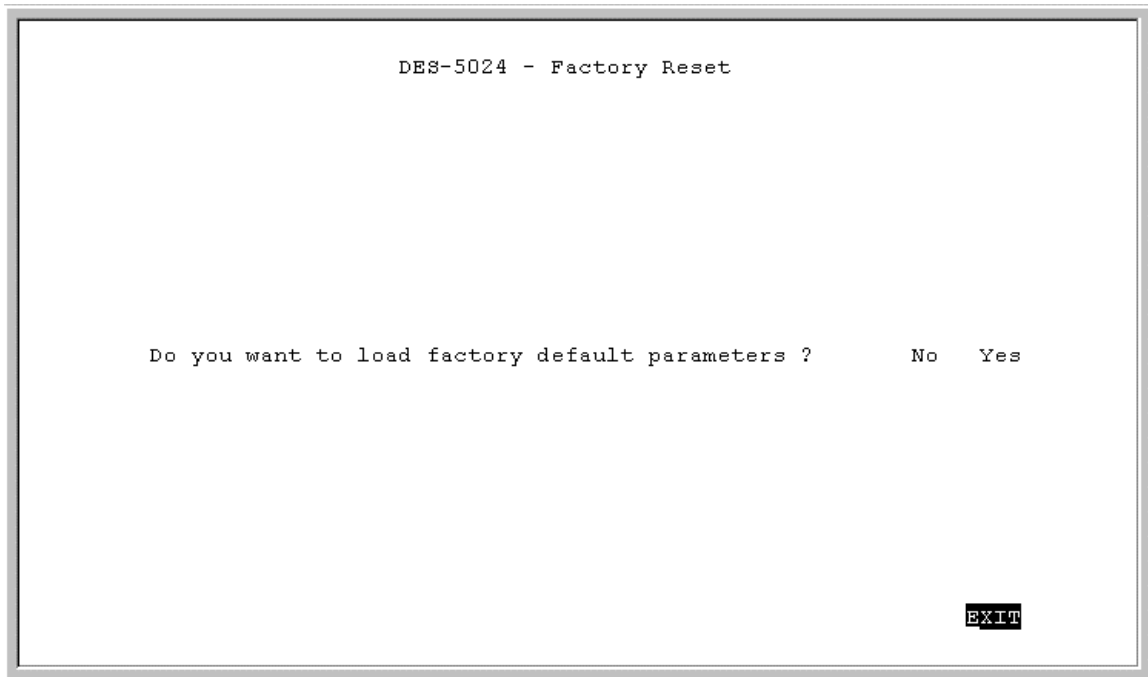

Figure 21: Factory Reset

Follow these steps to restore factory default configurations:

1. Select Yes
2. Press Enter.

You will see a confirmation panel, displayed in Figure 22. Select Yes to confirm your choice. Select No to return to the System Configuration menu.

To exit without resetting:

1. Select No or EXIT.
2. Press Enter.

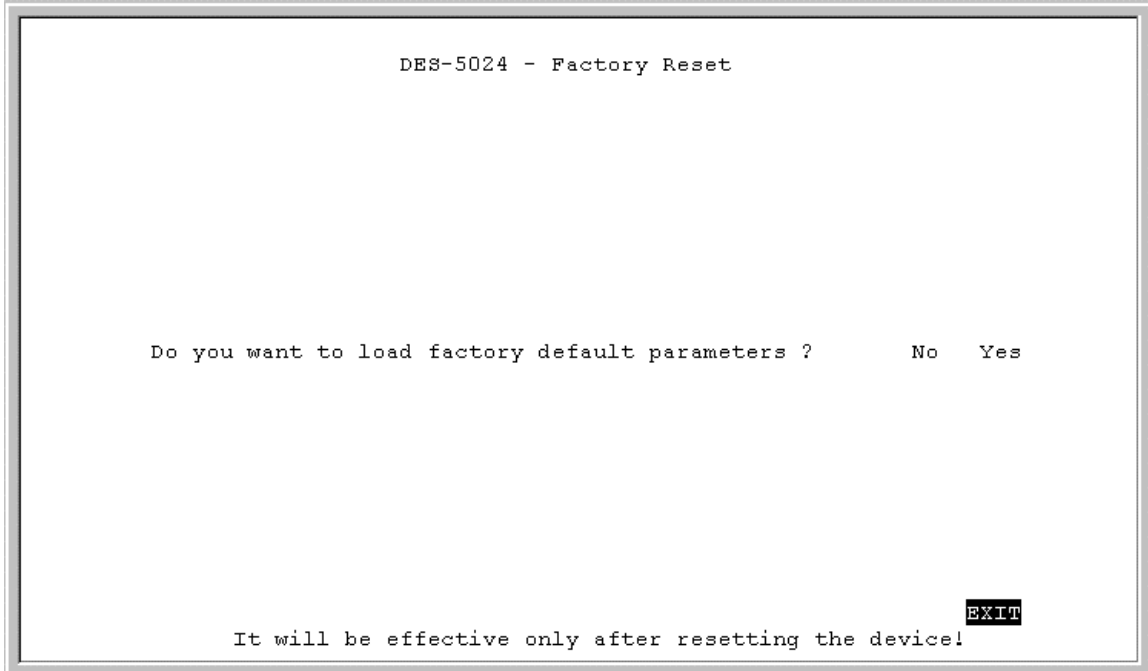

Figure 22: Factory Reset confirmation

Follow these steps to exit the panel without restoring factory default parameters:

1. Select No or Exit.
2. Press Enter.

System Rate Control

The System Rate Control panel, displayed in Figure 23, allows you to set the packet forwarding rate on the DES-5024. There are two options: Store & Forward and Cut-Through.

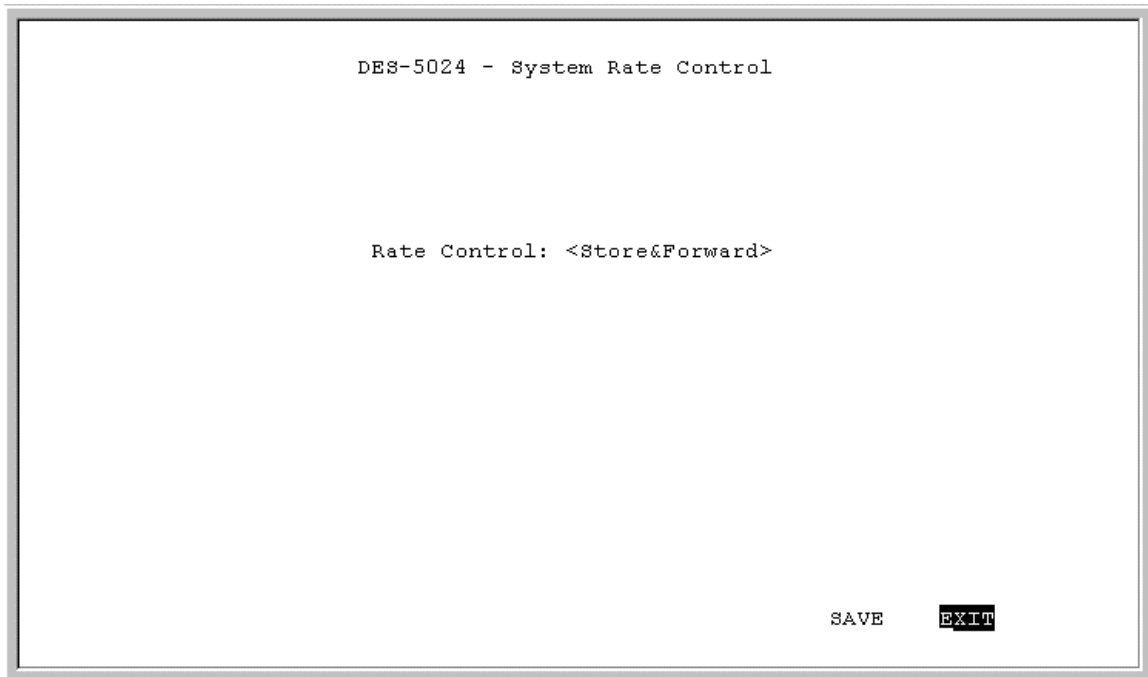

Figure 23: System Rate Control

The DES-5024 can be set for Store and Forward or Cut-Through. This is a global setting that affects all the ports except the RS-232 port.

Store and Forward means that when the DES-5024 receives an incoming packet it “stores” the packet until the entire data packet has been received before it “forwards” the packet to a destination.

In Cut-Through mode the DES-5024 begins sending out the packet as soon as it receives the first 128 bytes of data. The first 128 bytes contain the destination of the packet.

Advantages of Store and Forward

Store and Forward only sends out valid data packets. Bad packets created by collisions on the network or damaged packets are filtered out.

Always use Store and Forward when some devices on the network run at 10 Mbps and others run at 100 Mbps.

Disadvantages of Store and Forward

Store and Forward requires more time because it receives the whole packet before sending it out. Every byte buffered is an additional eight microseconds of delay. For

example, 1500 byte packets are delayed by 1200 microseconds in a Store and Forward device versus 60 microseconds in a Cut-Through device.

Store and Forward requires more memory because the DES-5024 must store the packet before sending it out.

Advantages of Cut-Through

Cut-Through is faster because the packet is sent as soon as the first 128 bytes are received.

Cut-Through requires less memory since the DES-5024 only reads the address but does not store the entire message.

Disadvantages of Cut-Through

Bad packets are perpetuated, taking up bandwidth.

The benefits diminish in high traffic networks.

Cut-Through can not be used on networks that use both Ethernet and Fast Ethernet. The network must use one or the other.

Follow these steps to change the default setting from Store and Forward to Cut-Through:

1. Toggle the space bar to change the setting.
2. Select Save and press Enter.

Software Update Menu

The Software Update menu, displayed in Figure 24, is used to upgrade the software on the DES-5024.

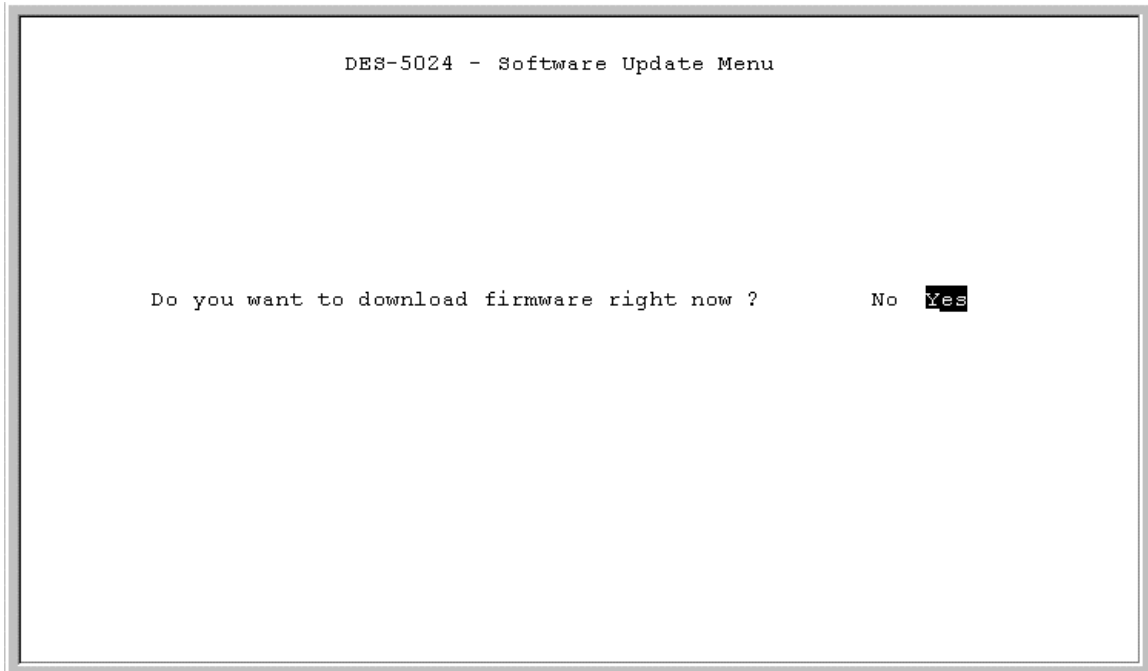

Figure 24: Software Update menu

Follow these steps to upload new software:

1. Load the new software to the hard drive of the PC you will be downloading from. Never attempt to load software from the floppy drive.
2. Connect the DES-5024 and the PC with the software on it with the RS-232 cable provided. Use the settings given at the beginning of this chapter. Never attempt to load firmware through Telnet.
3. Select Yes on the Software Update menu.
4. You will see the panel displayed in Figure 25. Select Transfer on the HyperTerminal menu bar at the top of the screen.
5. Select Browse on the panel displayed in Figure 25. The browse option shows the contents of your hard drive. You must specify the path from the DES-5024 to the file the firmware is in. Navigate to the file the firmware is stored in and select it. Use XMODEM displayed in Figure 26, to transfer the file.
6. The panel, displayed in Figure 27, will display statistics about the transfer, including the elapsed time and the time remaining.

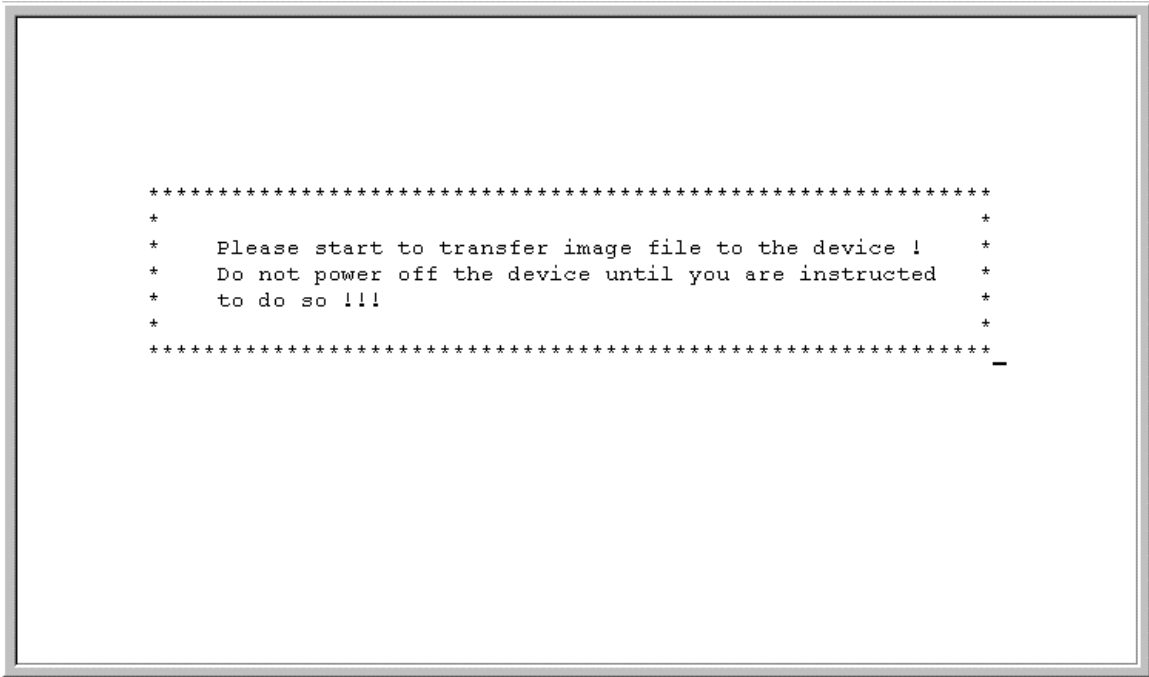

Figure 25: Transfer Firmware

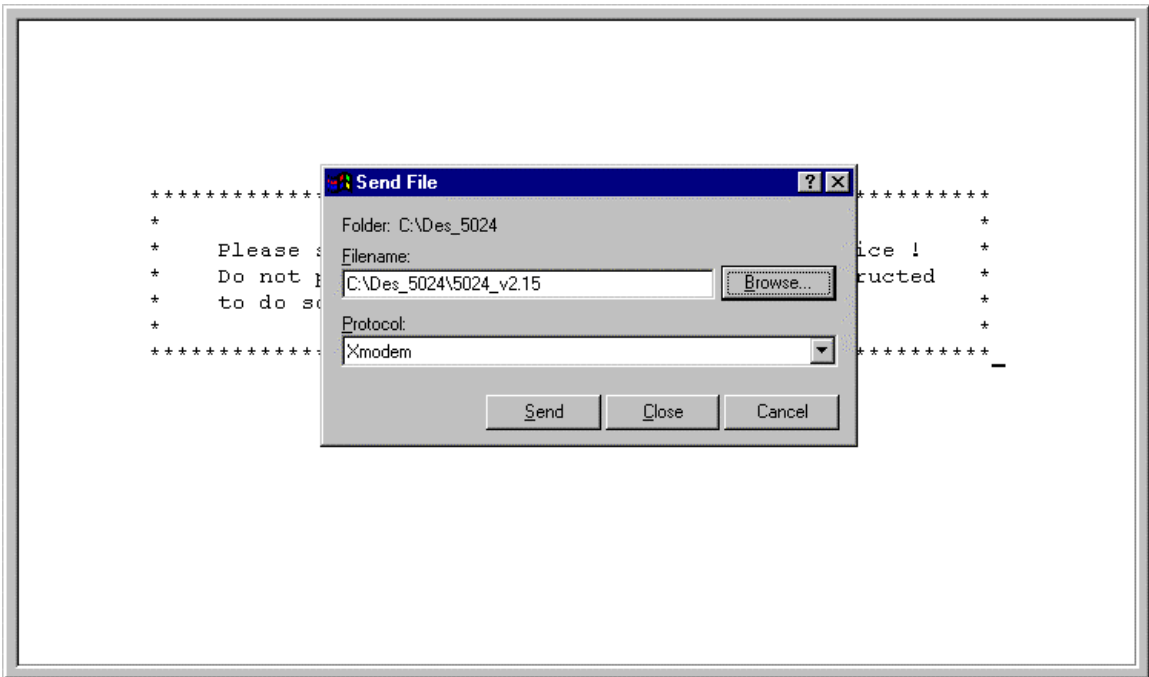

Figure 26: Send File

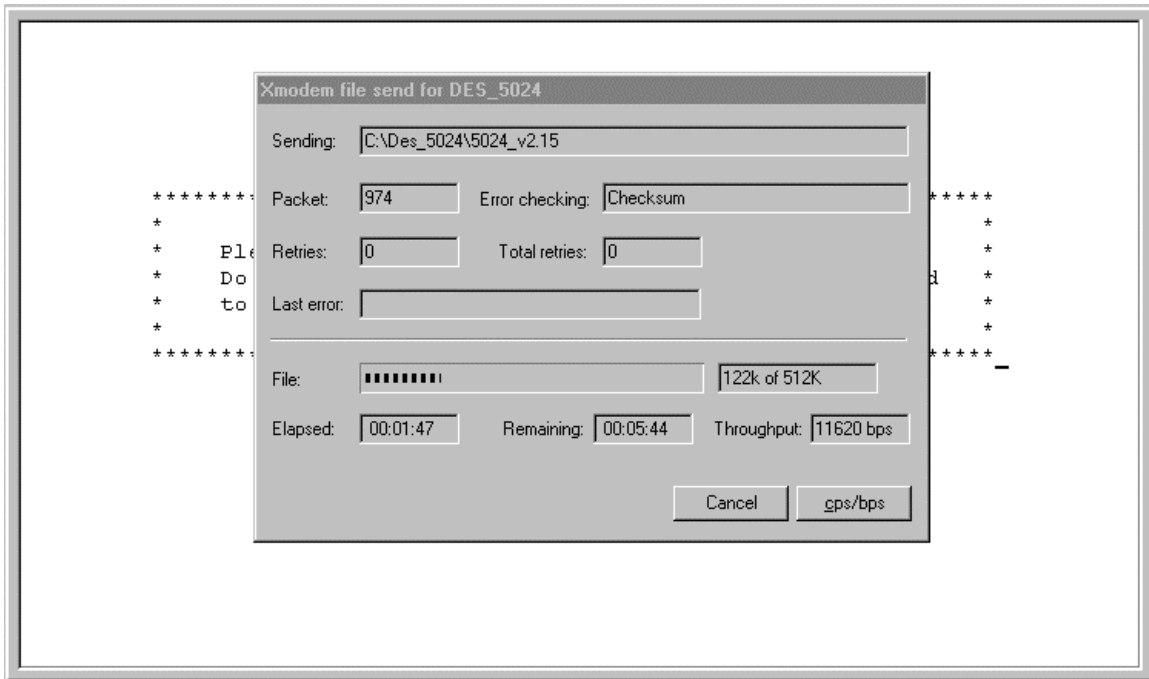

Figure 27: Xmodem

When the transfer is complete you will see the panel in Figure 28. The DES-5024 will reset itself automatically and you will have to log in again.

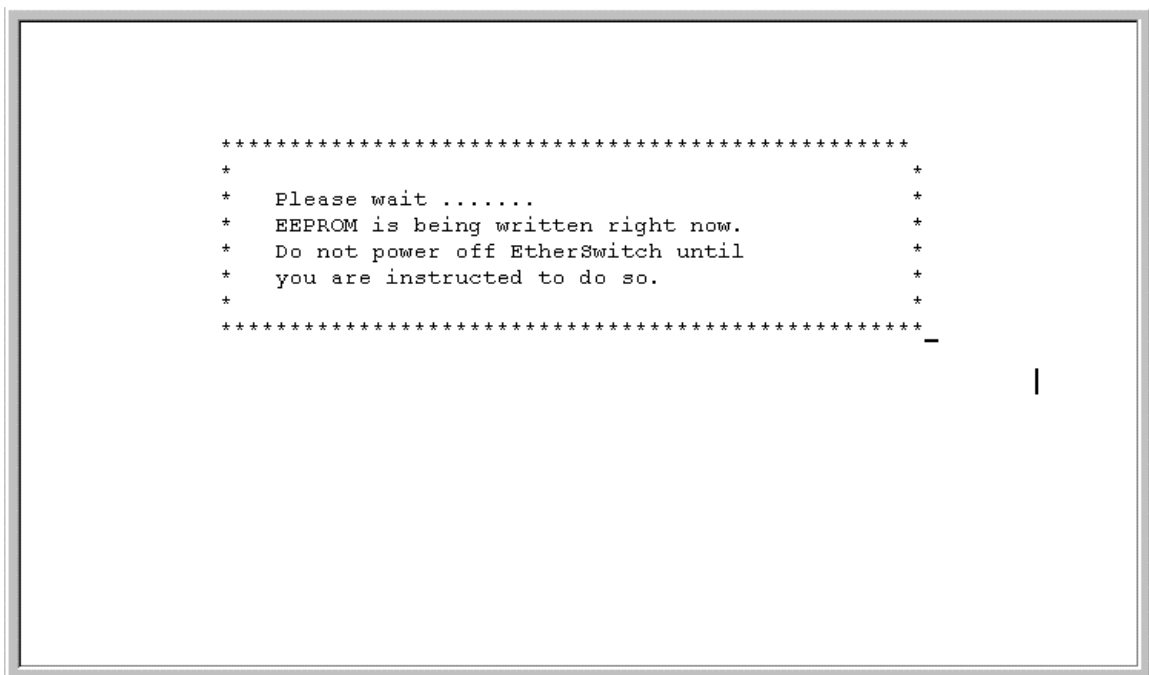

Figure 28: EEPROM

User Account Management

The User Account Management panels allow you to add users, delete users and modify user access rights.

Follow these steps to reach the User Account Management panels:

1. Select User Account Management on the Main menu.
2. Press Enter.

User Account Change Menu

The User Account Change menu, displayed in Figure 29, allows you to add users, delete users, and modify user rights.

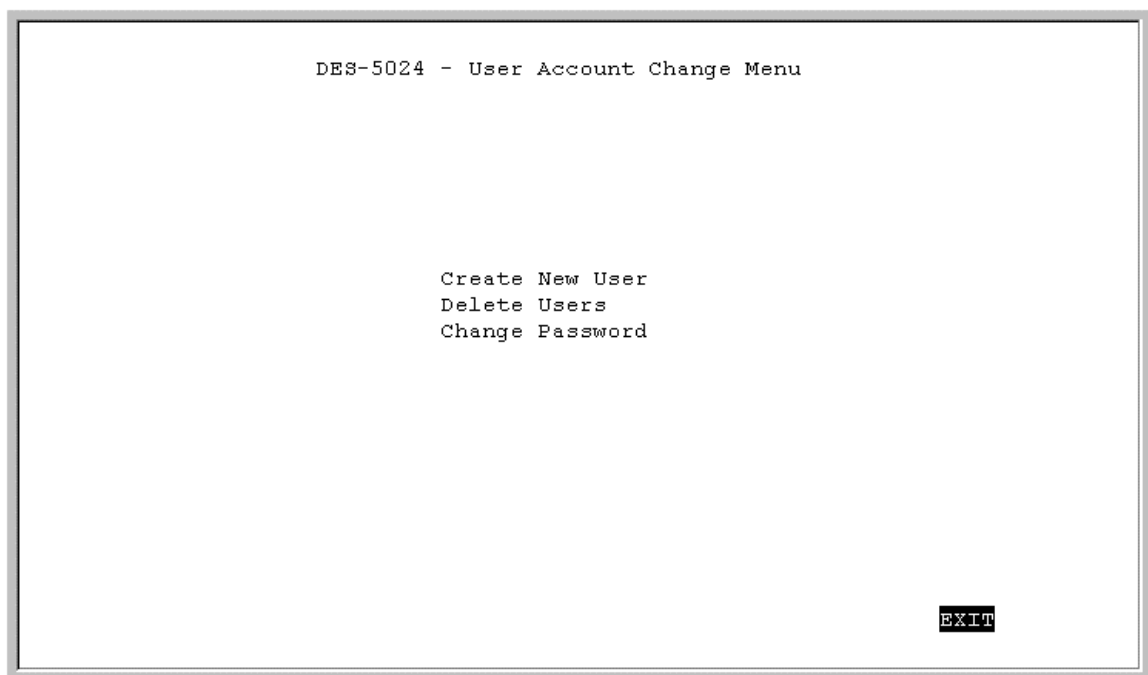

Figure 29: User Account Change

Follow these steps to select a menu option:

1. Select an option.
2. Press Enter.

Create New User

The Create New User panel, displayed in Figure 30, allows you to add new users. You can have a total of three users on the DES-5024.

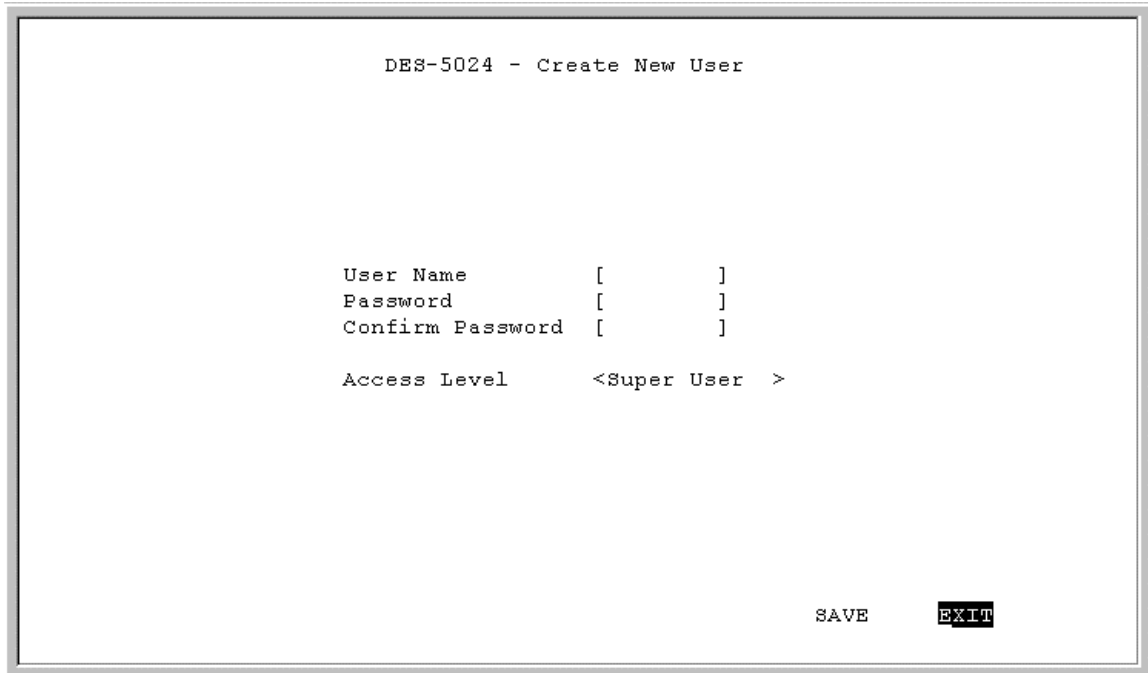

```
DES-5024 - Create New User

User Name      [          ]
Password       [          ]
Confirm Password [          ]

Access Level   <Super User >

SAVE          EXIT
```

Figure 30: Create New User

User Name

Enter the user's name in this field. User names are case sensitive. You can enter a maximum of eight characters.

Password

Enter the user's password in this field. Passwords are case sensitive. You can enter a maximum of eight characters.

Confirm Password

Reenter the user's password to confirm it in this field.

Access Level

There are two access levels available on the DES-5024: Super User and General User.

Super Users have administrative rights on the DES-5024. They can add and delete users, change the configuration of the DES-5024 and perform all management functions.

General Users have read only access to the DES-5024. They can look at the panels but they cannot make any changes to existing settings or configurations.

Follow these steps to add users:

1. Enter the User Name.
2. Enter the Password.
3. Reenter the password in the Confirm Password field.
4. Toggle the space bar to set the access level of the new user.
5. Select Save and press Enter.

Delete Users

The Delete Users panel, displayed in Figure 31, allows you to delete users from the DES-5024. As a safety precaution, the DES-5024 will not allow the user who is currently logged in to delete themselves by accident.

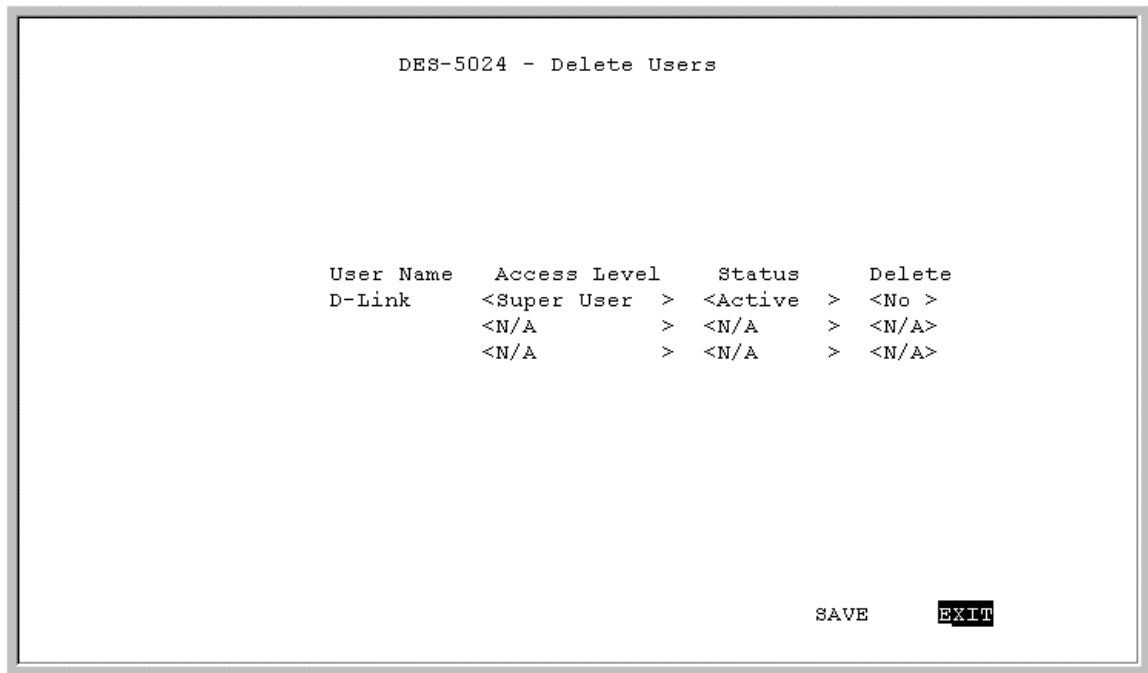

Figure 31: Delete Users

User Name

Identifies the users listed on the DES-5024.

Access Level

Determines whether the user is a Super User with full administrative rights on the network or a General User with read only access rights.

Status

A user's status can be active or inactive. Only active users can log in and make changes. Inactive users cannot.

Delete

Enables you to delete users.

The following operations can be performed independently of each other or combined.

Follow these steps to change user Access Level:

1. Select the user's Access Level.

2. Toggle the space bar to change the current Access Level.
3. Select Save and press Enter.

Follow these steps to change user Status Level:

1. Select the user's Status Level.
2. Toggle the space bar to select the new Status Level.
3. Select Save and press Enter.

Follow these steps to delete users:

1. Select the Access Level of the user you want to delete.
2. Move the cursor to the Delete column and use the space bar to toggle the option from No to Yes.
3. Press Enter.
4. Select Save and press Enter.

Change Password

The Change Password panel, displayed in Figure 32, enables you to change user passwords.

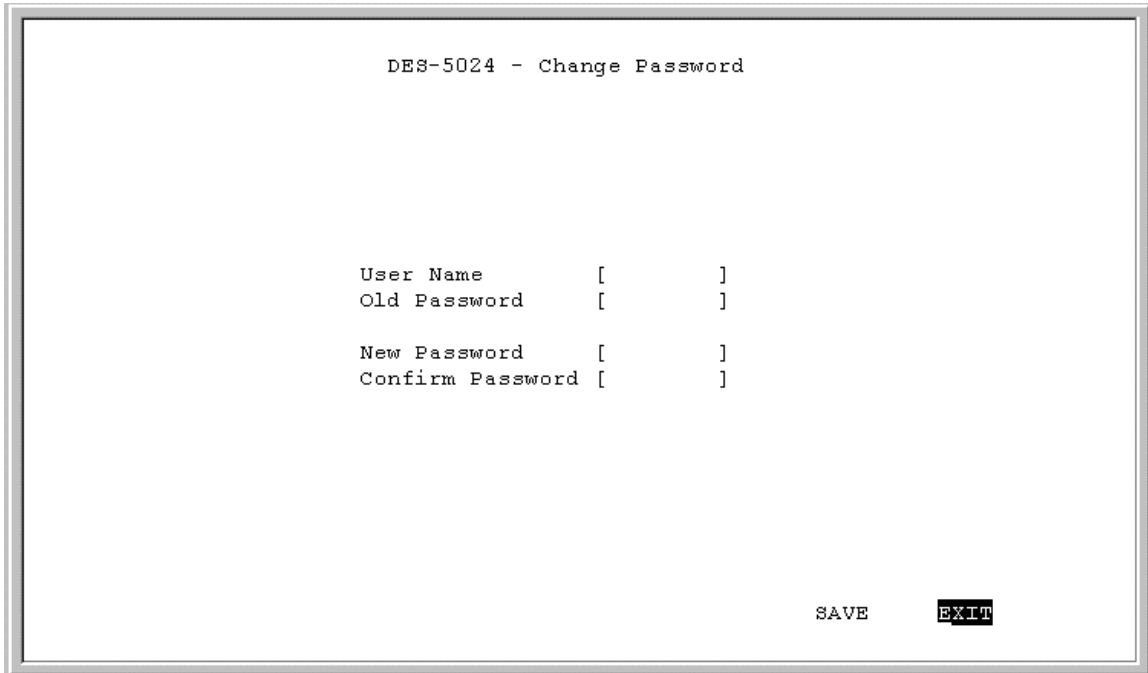

```
DES-5024 - Change Password

User Name      [      ]
Old Password   [      ]

New Password   [      ]
Confirm Password [      ]

SAVE           EXIT
```

Figure 32: Change Password

User Name

The name of the user whose password you are going to change.

Old Password

The user's old password.

New Password

The user's new password.

Confirm Password

Reenter the new password in this field to confirm it.

Follow these steps to change user passwords:

1. Enter the user's name in the User Name field.
2. Enter the user's old password in the Old Password field.
3. Enter the new password in the New Password field.
4. Reenter the new password in the Confirm Password field.

5. Select Save and press Enter to save your changes.

Switch Port Configuration

The Switch Port Configuration panels are used to configure individual ports on the DES-5024. The only difference between the panels is the port number that they deal with. The options and settings are the same for each. Select the group of ports that you want to configure and then go to the appropriate panel.

Follow these steps to select a panel:

1. Decide which group of ports you would like to work with.
2. Select the group on the Console Program panel.
3. Press Enter to go to the appropriate panel.

Switch Port Configuration Menu

The Switch Port Configuration menu, displayed in Figure 33, enables you to change the configurations of individual ports.

```

DES-5024 - Switch Port Configuration Menu

Port/1 State:      <Enable >      Port/5 State:      <Enable >
  Physical:        <Auto >        Physical:          <Auto >
  Port State:      Forwarding      Port State:        Forwarding
  Priority[0-255]: [128]           Priority[0-255]:   [128]
Port/2 State:      <Enable >      Port/6 State:      <Enable >
  Physical:        <Auto >        Physical:          <Auto >
  Port State:      Forwarding      Port State:        Forwarding
  Priority[0-255]: [128]           Priority[0-255]:   [128]
Port/3 State:      <Enable >      Port/7 State:      <Enable >
  Physical:        <Auto >        Physical:          <Auto >
  Port State:      Forwarding      Port State:        Forwarding
  Priority[0-255]: [128]           Priority[0-255]:   [128]
Port/4 State:      <Enable >      Port/8 State:      <Enable >
  Physical:        <Auto >        Physical:          <Auto >
  Port State:      Forwarding      Port State:        Forwarding
  Priority[0-255]: [128]           Priority[0-255]:   [128]

                                     SAVE   EXIT

```

Figure 33: Switch Port Configuration

State

All ports have two states: enabled or disabled. Enabled ports transmit and receive data packets. Disabled ports can not transmit or receive packets. You can disable a port but you will not be able to use a disabled port.

Physical

Refers to the physical state of the port. If you manually change the state of a port it will remain in that state until you change it. It will not auto negotiate speed and duplex mode. All TX ports can be in the following physical states:

- Auto
- 100Tx/Half
- 100Tx/Full
- 10Tx/Half
- 10Tx/Full

Ports in the Auto state automatically negotiate speed and duplex mode. This is the default setting.

Ports set in the 100Tx/Half physical state are set to work at 100 Mbps half duplex.

Ports set in the 100Tx/Full state are set to work at 100 Mbps full duplex.

Ports set in the 10Tx/Half state are set to work at 10 Mbps half duplex.

Ports set in the 10Tx/Full state are set to work at 10 Mbps full duplex.

The 100BASE-FX ports can only be in the 100/Fx Half or 100/Fx Full states. The 1000BASE-FX port can only be in 1000SX/Full. Half-duplex operation is not supported in the Gigabit Module.

Port State

All ports have four states: blocking, listening, learning and forwarding. Blocking means that nothing is coming through the port. If the Spanning Tree Algorithm detects a loop it will change the state of the port where the loop is detected to the Blocking State. You can disable the Spanning Tree Algorithm. Forwarding means the port is forwarding data packets to their destination. Listening means that the port is listening for data packets. Learning means the port is learning the MAC address for data packets. This setting cannot be manually changed.

Priority

The port priority can be set from zero to 255. Zero is the highest port priority. The port assigned a zero will be the root port. The default setting will work in most situations.

Flow Control

The 1000BASE-SX module allows you to enable or disable flow control. Flow control allows the module to stop the flow of information from another device.

Follow these steps to change the port state:

1. Select the State setting of the appropriate port.
2. Toggle the space bar to change the current setting.
3. Select Save and press Enter.

Follow these steps to change a port's physical state:

1. Select the physical setting of the appropriate port.
2. Toggle the space bar until you find the appropriate setting.
3. Select Save and press Enter.

Follow these steps to change the port priority:

1. Select the priority of the appropriate port.
2. Enter a new value between zero and 255.
3. Select Save and press Enter.

Follow these steps to enable or disable flow control:

1. Toggle the space bar to enable or disable flow control.
2. Select Save and press Enter.

Spanning Tree Configuration

The Spanning Tree Configuration panel is used to configure the Spanning Tree Algorithm. The Spanning Tree Algorithm (STA) in the DES-5024 allows you to create alternative paths (using multiple switches or bridges) in your network. These backup paths are idle until the DES-5024 determines that a problem has developed in the primary path. If the primary path breaks down STA will activate the backup path. STA is very complicated and you should understand it well before changing the default settings. See Table 7: User Selective STA Parameters.

STA Operation Levels

STA operates on the bridge level and the port level. On the bridge level, STA calculates the Bridge Identifier for each DES-5024, then sets the Root Bridge and the Designated Bridges. On the port level, STA sets the Root Port and Designated Ports.

Spanning Tree Configuration Menu

The Spanning Tree Configuration menu, displayed in Figure 34, allows you to enable or disable STA, set bridge priority and other configurations.

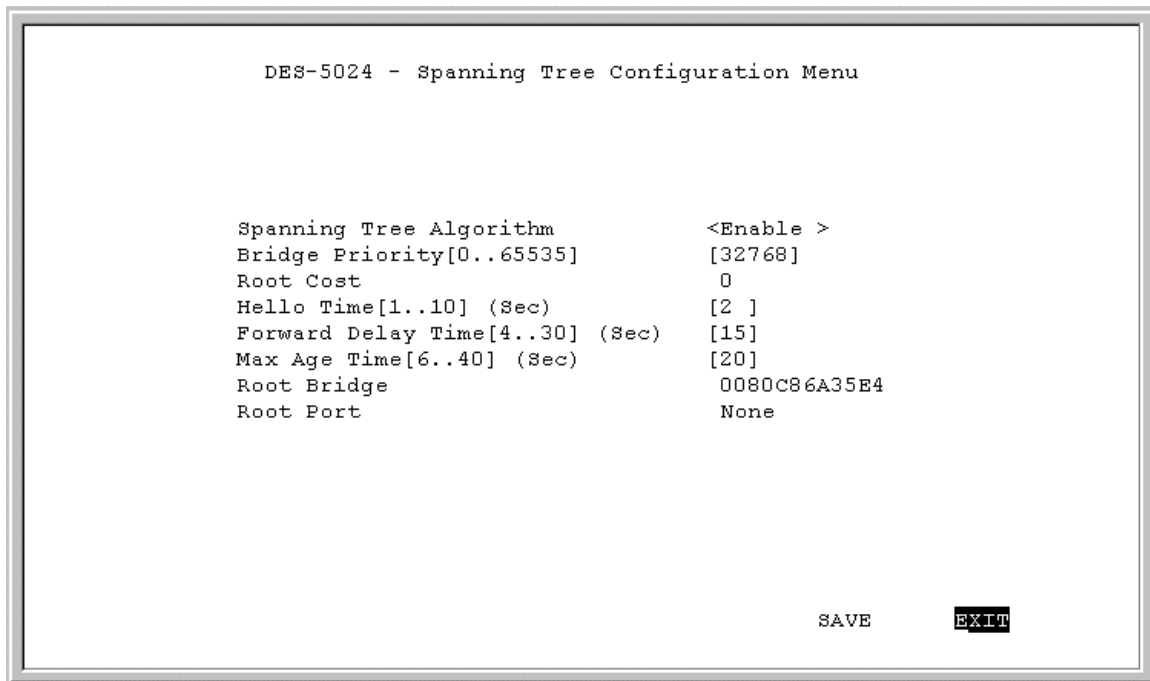

```
DES-5024 - Spanning Tree Configuration Menu

Spanning Tree Algorithm      <Enable >
Bridge Priority[0..65535]    [32768]
Root Cost                    0
Hello Time[1..10] (Sec)     [2 ]
Forward Delay Time[4..30] (Sec) [15]
Max Age Time[6..40] (Sec)   [20]
Root Bridge                  0080C86A35E4
Root Port                    None

                               SAVE   EXIT
```

Figure 34: Spanning Tree Configuration

Spanning Tree Algorithm

Spanning Tree Algorithm can be enabled or disabled. Use Spanning Tree to prevent network loops.

Bridge Priority

The Bridge Priority can be from 0 to 65535. Zero is the highest Bridge Priority. The higher the Bridge Priority the greater the chance that the DES-5024 will be selected as the Root Bridge. The DES-5024 with the highest Bridge Priority is the Root Bridge.

Root Cost

The Root Cost is the number of times a packet is regenerated before reaching its destination. A source sends a packet to the first device (switch or hub) on the network. When the packet reaches the next hub or switch and is sent out again, the Path Cost becomes two. Each switch and active hub regenerates the packet. To determine the Root Path Cost, count the number of times the packet is regenerated.

The switch with the lowest Path Cost is the Root Bridge. Make the Root Bridge the best switch on the network.

Hello Time

Is the interval between two transmissions of packets sent by the Root Bridge to tell all other switches that it is the Root Bridge. The Hello Time can be set manually, with a range in seconds from 1 to 10. If the Hello Time is set for the switch and the switch is not the Root Bridge then the Hello Time will not take effect until the switch becomes the Root Bridge.

Forward Delay Time

This is the time any port on the DES-5024 spends in the listening state while moving from the listening state to the forwarding state. It can be set from 4 to 30 seconds.

Use the following formula when setting the Hello Time and the Forward Delay Time:

$$2 \times (\text{Forward Delay minus 1 second}) \geq \text{Max Age}$$

$$2 \times (\text{Hello Time plus 1 second}) \leq \text{Max Age}$$

Max Age Time

Is the time a non-root bridge waits for a packet to be sent. At the end of the Max Age, if a packet has not been received from the Root Bridge, the DES-5024 will start sending its own packets and request permission to become the Root Bridge. If it turns out that the DES-5024 has the lowest Bridge Identifier it will become the Root Bridge.

The switch with the lowest Bridge Identifier is the Root Bridge. It is best to make the Root Bridge the best switch on the network to ensure the best network performance and reliability.

Root Bridge

Specifies the MAC address of the Root Bridge. The DES-5024 may or may not be the root bridge. The DES-5024 is the default root bridge.

Root Port

Specifies the preferred path to the Root Bridge. Only one path per bridge can exist. The default setting is none.

Table 7: User Selective STA Parameters

STA parameters	Settings	Effects	Comment
Enable/Disable	Enable/Disable	Participate in or remove from STA	Enable in a SNMP network.
Bridge Priority	Lower the #, higher the priority	Increases chance of becoming the Root Bridge	Avoid, if the switch is used in workgroup level of a large network
Hello Time	1 – 10 seconds	No effect, if not Root Bridge	Never set greater than Max Age Time
Max Age Time	6 – 40 seconds	Compete for Root Bridge, if BPDU is not received	Avoid low number for unnecessary reset of Root Bridge
Forward Delay	4 – 30 seconds	High # delays the change in state	Max Age \leq 2 x (Forward Delay - 1) Max Age \geq 2 x Hello Time + 1)
Port Level STA parameters			
Enable/ Disable	Enable/ disable	Enable or disable LAN segment	Disable a port for security or problem isolation
Port Priority	Lower the #, higher the priority	Increases chance of becoming the Root Port	

SNMP Management Configuration

The SNMP Management Configuration panel is used to configure the DES-5024 for SNMP management. Leave the default values in place if you are not managing your network through SNMP.

The DES-5024 uses the standard MIB-II Management Information Base module. The MIB values can be retrieved from any SNMP based network manager. The DES-5024 supports its own proprietary enterprise as an extended MIB. The MIB can be retrieved by specifying their Object-Identity (OID). MIB values can be either read-only or read-write.

Read-only MIB variables can be constants that are programmed into the DES-5024 or variables that change while the DES-5024 is running. For example, the number and type of ports on the DES-5024 is a read-only constant. The number and type of ports is fixed. Statistics, such as the number of errors that have occurred, are read-only variables.

Read-write MIBs are usually related to user customized configurations. Examples of these are the DES-5024's IP address, STA parameters and port status.

If you use third party vendors' SNMP software to manage the DES-5024, a diskette listing the DES-5024's proprietary enterprise MIB can be obtained by request. If your software provided functions to browse or modify MIB, you can get the MIB values and change them (if the MIB's attributes permit the write option). This process can be difficult. You must know the MIB OIDs and retrieve them one by one.

SNMP Management Configuration Menu

The SNMP Management Configuration menu, displayed in Figure 35, enables you to configure the DES-5024 for SNMP management.

```

DES-5024 - SNMP Management Configuration Menu

SNMP Manager Setting

SNMP Community String      Access Right      Status
[public                    ] <Read Only >    <Valid >
[private                   ] <Read/Write>    <Valid >
[                           ] <Read Only >    <Invalid>
[                           ] <Read Only >    <Invalid>

SNMP Trap Manager Setting

IP Address      SNMP Community String      Status
[0.0.0.0        ] [                           ] <Invalid>
[0.0.0.0        ] [                           ] <Invalid>
[0.0.0.0        ] [                           ] <Invalid>
[0.0.0.0        ] [                           ] <Invalid>

SAVE      EXIT

```

Figure 35: SNMP Management Configuration menu

SNMP Manager Setting

The fields under this setting are used to configure the DES-5024 for SNMP Management. You must configure these fields in order to manage the DES-5024 through SNMP.

SNMP Community String

The SNMP Community String field allows you to name the SNMP Communities. The names public and private are only default names. For security you should change these names to help prevent unauthorized access to the DES-5024.

You can name the SNMP communities anything you like. You can enter up to 32 characters in each of the four fields. You can create up to four SNMP Communities.

Access Right

Enables you to set the rights that members of the SNMP Communities have. Read Only access rights mean that members of the community can view the information on the DES-5024 but they can not make changes to the configurations. Read/ Write access rights allow the members of the community to make any changes they desire.

Status

Can be Valid or Invalid. Only communities with Valid status can access the DES-5024. Communities with Invalid status cannot access the DES-5024.

SNMP Trap Manager Setting

Enables you to enter the IP addresses of Trap Managers. Traps are messages the DES-5024 sends out to inform trap managers of events on the network. The DES-5024 generates traps and sends them to the network manager. Trap managers are special network users who are given certain rights and access to oversee and maintain the network. This feature is available only in D-View or by using other SNMP management software.

You can specify which network managers may receive traps from the DES-5024 by creating a list of IP Addresses of the authorized network managers.

Trap managers can receive the following trap types:

- Cold Start
- Authentication Failure
- Link Change Event

Cold Start

Signifies that the DES-5024 has been powered up. Software settings are reconfigured and hardware systems are rebooted. A cold start is different from a factory reset.

Authentication Failure

Signifies that an addressee (or manager/ user) on the DES-5024 is not a valid user of the DES-5024 and may have entered an incorrect community name.

Link Change Event

Signifies that the link of a port has changed from link up to link down or vice versa.

IP Address

This field is used to enter the IP Addresses of Trap Managers.

SNMP Community String

Enter the Community String of the Trap Managers in this field.

Status

The DES-5024 will not send out traps unless the status is Valid.

Follow these steps to enter the SNMP Community String:

1. Enter the name of the SNMP Community.

2. Select the Access Right field and toggle the space bar to select Read Only or Read/Write.
3. Select the Status field and toggle the space bar to select Valid or Invalid.
4. Select Save and press Enter.

Follow these steps to configure the SNMP Trap Manager Setting:

1. Enter the IP Address of the Trap Manager.
2. Enter the name of the SNMP Community String.
3. Select Status and toggle the space bar to select Valid or Invalid.
4. Select Save and press Enter.

VLAN Port Management

A Virtual Local Area Network (VLAN) is a logical subgroup within a LAN that is created with software rather than physical connections. The purpose of a VLAN is to prevent broadcast storms and ease congestion on your network.

Each VLAN created is a broadcast domain. A broadcast is a packet that is sent to all nodes on the network. A broadcast domain is a domain in which every node in the domain receives the broadcast packet. The advantage of creating VLANs is that they permit you to group LAN segments together in order to get the most out of your network.

VLANs become more important as the network grows and traffic increases. VLANs are usually used on high traffic networks. You should consider a VLAN on a smaller network if a department or workgroup routinely does tasks that take up a lot of bandwidth and they are not already on their own LAN segment.

VLANs can be used to subdivide the network. The DES-5024 supports port based VLAN. Port based VLAN means that the VLAN is grouped by port. If a VLAN is created using three ports, then those ports become a separate broadcast domain.

By using VLANs, members of a particular department or workgroup can be partitioned from the rest of the network. For example, the marketing department can be on one VLAN and the accounting department can be on another. If a workstation in marketing sends a broadcast packet to another workstation in marketing the packet will remain in the marketing VLAN.

VLAN Port Management Menu

The VLAN Port Management menu, displayed in Figure 36, enables you to create, delete and modify VLANs on the DES-5024.

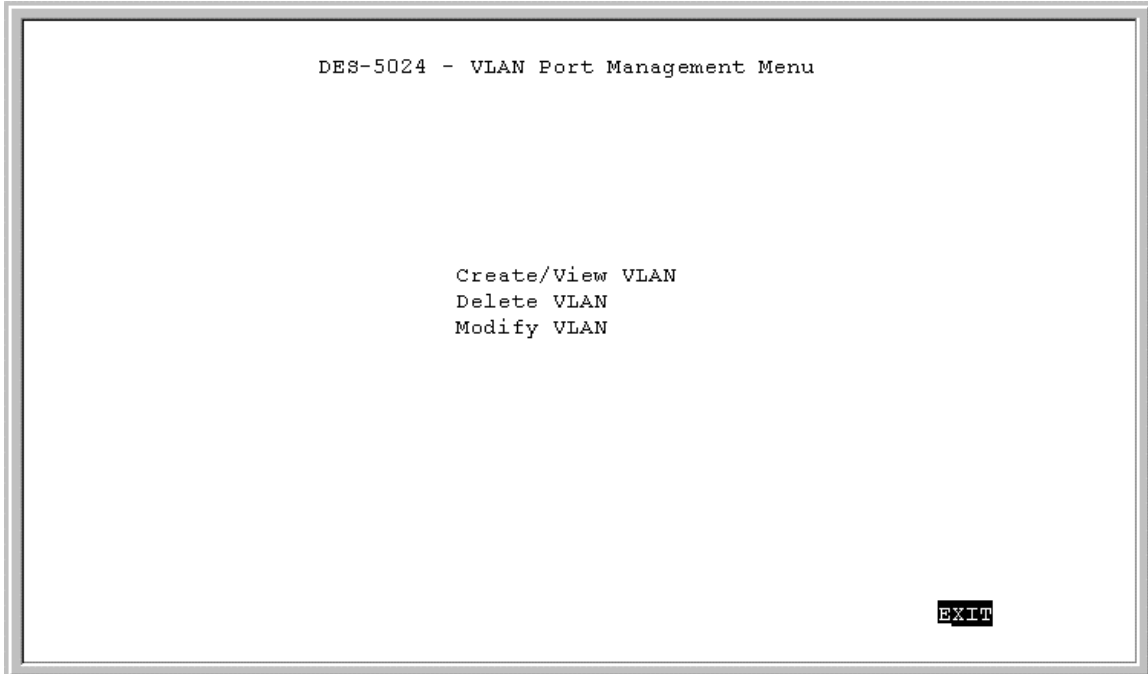

Figure 36: VLAN Port Management menu

Follow these steps to create, delete and modify VLAN:

1. Select the appropriate option.
2. Press Enter.

Create New VLAN

The Create New VLAN menu, displayed in Figure 37, is used to create a new VLAN. The default value is that all ports belong to one VLAN. You can create up to eight separate VLANs. Ports can belong to two VLANs at the same time. Each VLAN is a broadcast domain. If you have created a trunking group, you must include the entire trunk group in the VLAN.

```

DES-5024 - Create New VLAN Menu

NEW VLAN Name: [      ]

port #      TrunkGroup  status      port #      TrunkGroup  status
Port 1      :          <Available> Port 13/25:          <Available>
Port 2      :          <Available> Port 14/26:          <Available>
Port 3      :          <Available> Port 15   :          <Available>
Port 4      :          <Available> Port 16   :          <Available>
Port 5/9    :          <Available> Port 17/21:          <Available>
Port 6/10   :          <Available> Port 18/22:          <Available>
Port 7/11   :          <Available> Port 19/23:          <Available>
Port 8/12   :          <Available> Port 20/24:          <Available>

                                     SAVE      EXIT

```

Figure 37: Create New VLAN menu

New VLAN Name

Is the name of the VLAN you are creating. All VLANs must have a unique name.

Port

Is the number of the port. The numbers on the panel match the ports on the DES-5024. Some ports are combined. For example, ports 5 and 9 are shown as “Port 5/9”. Ports that are grouped together must be part of the same VLAN.

TrunkGroup

This field identifies the trunk group that the port has been assigned to. The field is open if the port has not been assigned to a Trunk Group.

Status

The status field can be either available or selected. Available indicates that the port is available for inclusion in a VLAN. Selected indicates the port has been assigned to a

VLAN. All ports will have a status of available on this panel, even after they have been selected as part of a VLAN. There is nothing on this panel that indicates the port is already part of a VLAN.

Follow these steps to create a VLAN:

1. Enter the name of the VLAN you are creating.
2. Select the ports you want to include in the VLAN and toggle the space bar to change the status from Available to Selected.
3. Select Save and press Enter.

Delete VLAN Menu

The Delete VLAN menu, displayed in Figure 38, is used to delete VLANs.

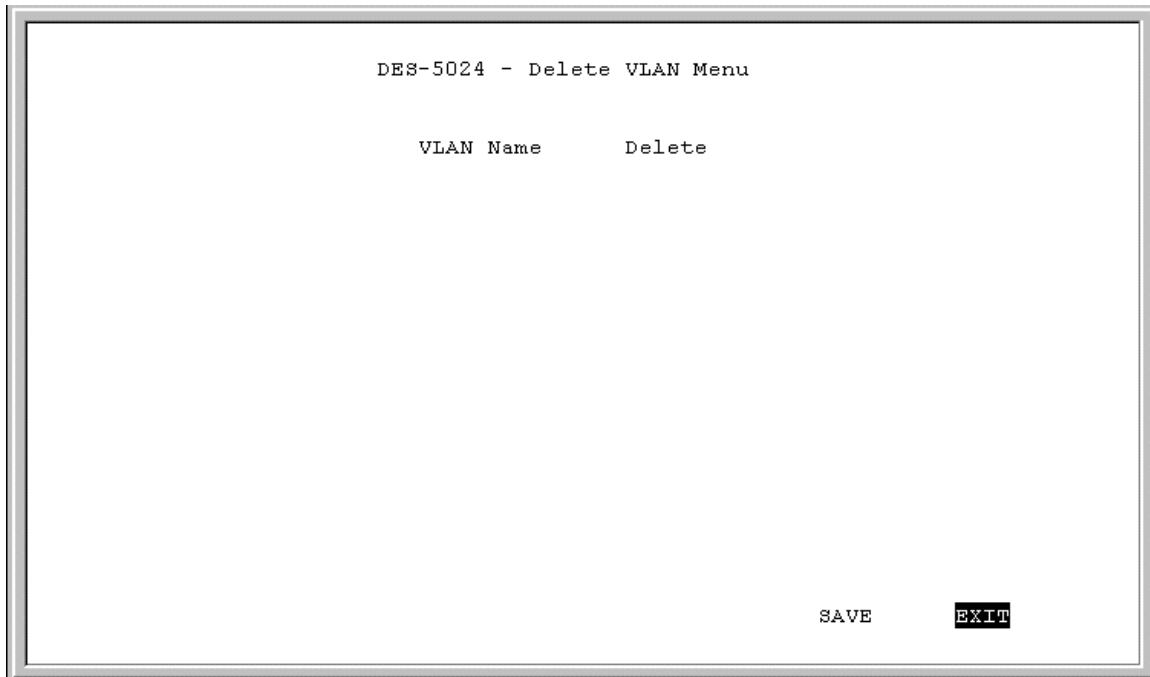

Figure 38: Delete VLAN menu

VLAN Name

Is the name of the VLAN.

Delete

After you have created a VLAN, this column will have the option to delete it.

Follow these steps to delete VLANs:

1. Select the VLAN you want to delete in the Delete column.
2. Toggle the space bar to Yes to delete the VLAN.
3. Select Save and press Enter.
4. A screen prompt will warn you that you must reset the DES-5024 in order for the change to take effect.

Modify VLAN Menu

The Modify VLAN menu, displayed in Figure 39, enables you to modify VLANs.

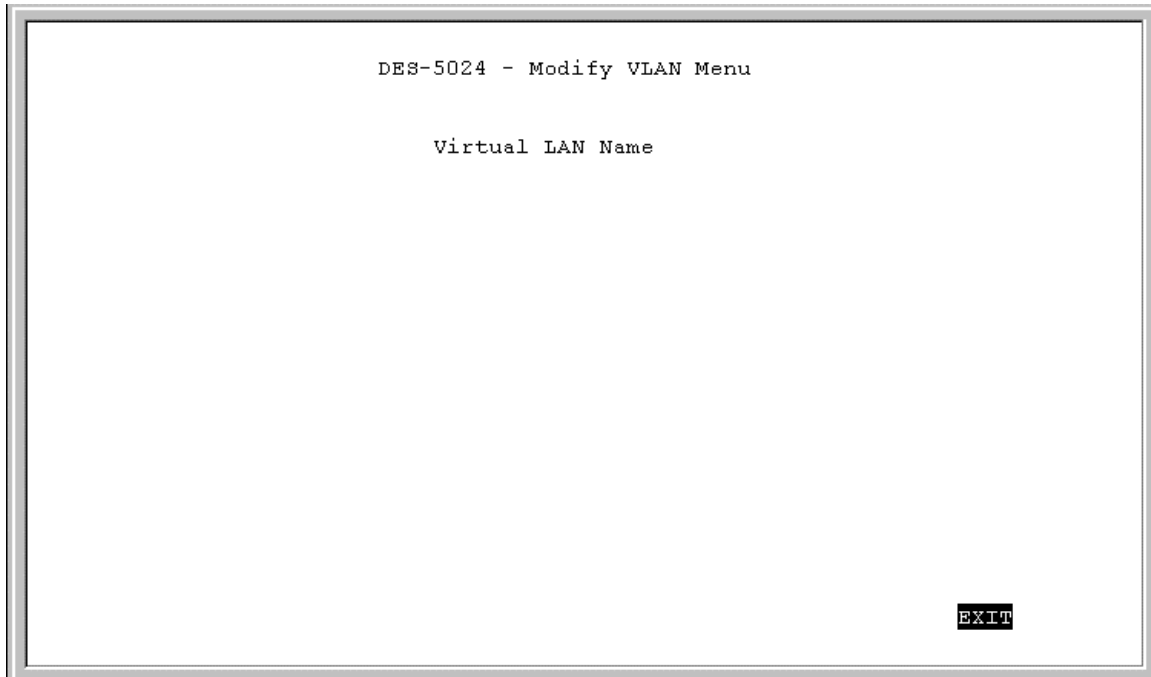

Figure 39: Modify VLAN menu

Virtual LAN Name

The names of all VLANs appear in this column.

Follow these steps to modify VLANs:

1. Select the name of the appropriate VLAN.
2. Press Enter.
3. You will see the VLAN Modify Menu. Use this panel to modify a VLAN.
4. Select the ports that you want to include in the VLAN or delete from the VLAN. Toggle the space bar to change the current setting. Available means the port is available for inclusion in the VLAN. Selected means the port has been selected as part of a VLAN.
5. Select Save and press Enter to implement your changes.

Trunking Port Management Menu

The Trunking Port Management panels, displayed in Figure 40, are used to create, delete and modify trunk ports.

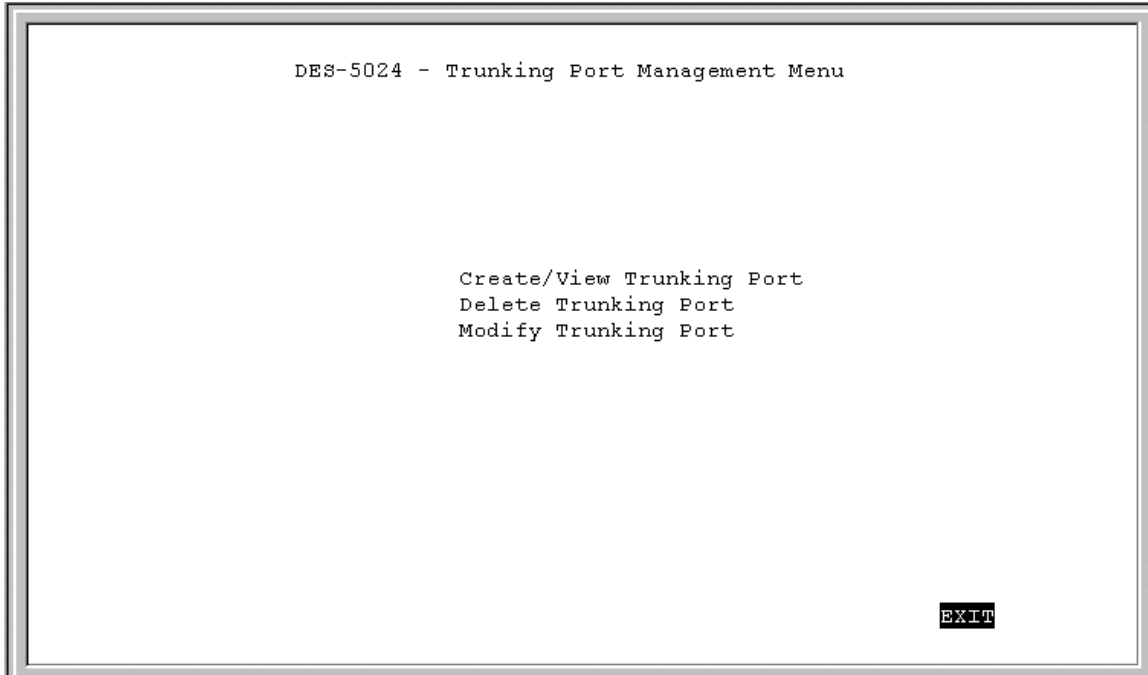

Figure 40: Trunking Port Management menu

Follow these steps to create, delete and modify trunk ports:

1. Select the appropriate option.
2. Press Enter.

Create New Trunking Port

The Create New Trunking Port panel, displayed in Figure 41, is used to create Trunk Ports. You can create up to seven trunking groups with up to eight ports in each group. Each Trunking Group acts like a single port. The trunking speed is 800 Mbps in half duplex and 1.6 gigabits in full duplex.

```

DES-5024 - Create New Trunking Port

New Trunking Group Name: [      ]

Port #   name   status   Port #   name   status
-----
Port 1:   <Available>
Port 2:   <Available>
Port 3:   <Available>
Port 4:   <Available>
Port 5:   < N/A >
Port 6:   < N/A >
Port 7:   < N/A >
Port 8:   < N/A >
Port 9:   <Available>
Port 10:  <Available>
Port 11:  <Available>
Port 12:  <Available>
Port 13:  <Available>
Port 14:  <Available>
Port 15:  <Available>
Port 16:  <Available>
Port 17:  < N/A >
Port 18:  < N/A >
Port 19:  < N/A >
Port 20:  < N/A >
Port 21:  <Available>
Port 22:  <Available>
Port 23:  <Available>
Port 24:  <Available>
Port 25:  < N/A >
Port 26:  < N/A >

SAVE      EXIT

```

Figure 41: Create New Trunking Port

New Trunking Group Name

Is the name of the Trunking Group you are going to create. All Trunking Groups must have a name.

Port

Is the number of the port. The numbers on the panel match the ports on the DES-5024. Some ports are not available for trunking. For example, port 5 has a status of N/A. Ports that are shown as N/A are not available for inclusion in any trunking groups.

Name

This field identifies the TrunkGroup that the port has been assigned to. The field is open if the port has not been assigned to a TrunkGroup.

Status

The status field can be either available or selected. Available indicates that the port is available for inclusion in a TrunkGroup. Selected indicates the port has been assigned to

a TrunkGroup. All ports will have a status of available on this panel, even after they have been selected as part of a TrunkGroup. There is nothing on this panel that indicates the port is already part of a TrunkGroup.

Follow these steps to create a TrunkGroup:

1. Enter the name of the TrunkGroup.
2. Select the ports you want to include in the TrunkGroup and toggle the space bar to change the status from Available to Selected.
3. Select Save and press Enter.

Delete Trunking Port

The Delete Trunking Port panel, displayed in Figure 42, is used to delete Trunk Ports.

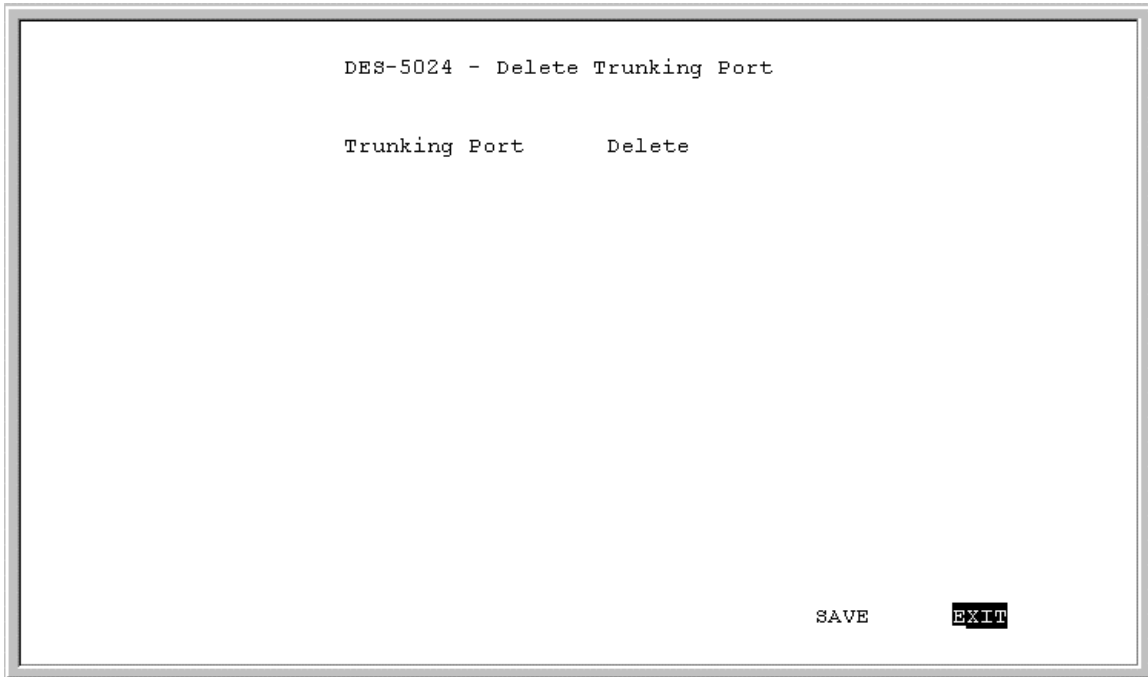

Figure 42: Delete Trunking Port

Trunking Port

Is the name of the Trunking Group.

Delete

After you have created a Trunking Group, this column will have the option to delete it.

Follow these steps to delete a Trunking Group:

1. Select the Trunking Group you want to delete in the Delete column.
2. Toggle the space bar to Yes to delete the Trunking Group.
3. Select Save and press Enter.

Modify Trunking Port

The Modify Trunking Port panel, displayed in Figure 43, enables you to Modify Trunking Ports.

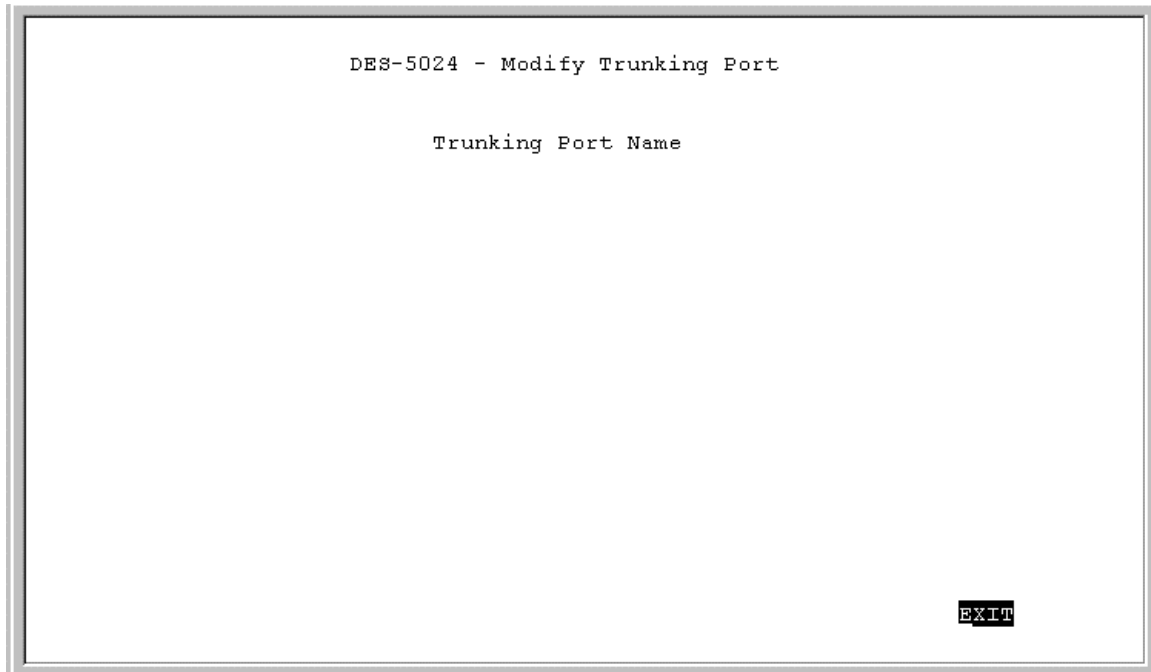

Figure 43: Modify Trunking Port

Trunking Port Name

The names of all Trunked Ports appear in this column.

Follow these steps to modify Trunked Ports:

1. Select the name of the appropriate Trunked Port.
2. Press Enter.
3. Use the Modify Trunking Port panel to modify a Trunking Group.
4. Select the ports that you want to include in the Trunking Group or delete from the Trunking Group. Toggle the space bar to change the current setting. Available means the port is available for inclusion in the Trunking Group. Selected means the port has been selected as part of a Trunking Group. N/A indicates ports that are not available for inclusion in any trunking group.
5. Select Save and press Enter to implement your changes.

Troubleshooting

This troubleshooting section is intended to help you solve the most common problems on the DES-5024.

The Diagnostic LED displays a code if there is a problem on the DES-5024. If an error cannot be resolved by implementing the solutions in this section, contact D-Link Technical Support.

All LEDs are explained in detail in Chapter 4, *LEDs*. If you are having a problem that is not discussed here, contact technical support.

Problem	Solution
POST Errors	<p>The DES-5024 performs a Power On Self Test (POST) every time it is powered on. If you are connected to the DES-5024 through Local Console Management during the POST you can see the results displayed on your monitor. The login screen appears after the DES-5024 has completed the POST.</p> <p>The POST checks all of the hardware components on the DES-5024. See Table 8: Diagnostic LED for proper actions.</p>
Cables	<p>Faulty cable is the most common source of problems on Ethernet and Fast Ethernet networks. Check the cable first if you are having any problems connecting to a device.</p> <p>Ethernet is more fault tolerant than Fast Ethernet. If you are moving from Ethernet to Fast Ethernet, make sure the cables are pinned out correctly. See Chapter 3, <i>Connecting the DES-5024 to the Network</i>, Cable Specifications, for a diagram showing the proper pin arrangement for Ethernet and Fast Ethernet.</p>
Port States	<p>All ports on the DES-5024 have two modes: auto negotiation mode and forced mode. Ports in auto negotiation mode auto negotiate the proper speed and duplex mode. Ports in forced mode have been manually set to a particular speed and duplex mode. Check the LEDs on the DES-5024 and on the link partner to verify settings. See Chapter 4, <i>LEDs</i>, for an explanation of all LEDs.</p> <p>The port settings on the DES-5024 and the port settings on the device you are connecting to must be the same in order for them to communicate. Check the speed and duplex setting on both the port and device you are connecting to.</p>
Power LED is Off	<p>Check the three pronged power plug and verify that you are getting power from the wall socket. If the DES-5024 is on and the power LED is not working properly return the DES-5024. If the DES-</p>

5024 is not powering on while the power cord is plugged into the wall socket, the power supply is not working. Return the unit.

All LEDs are Off Check the power plug and verify that the DES-5024 is receiving adequate power. Log in to the DES-5024 using Local Console Management, see Chapter 5, *Managing the DES-5024*, for instructions.

Power the DES-5024 off and then power it on again. Use the monitor to check the error messages. Return the DES-5024 to D-Link for service if the problem persists.

Forget Password If you forget your password, contact D-Link Technical Support at (949) 788-0805 for assistance or check our web site at www.dlink.com.

System Error LED Indicators	Error Status	Action
Off - ① ② ③ ④ ⑤ ⑥ ⑦ ⑧ On - ① ② ③ ④ ⑤ ⑥ ⑦ ⑧		Normal
① ② ③ ④ ⑤ ⑥ ⑦ ⑧	Boot Program Flash Damaged	Download firmware again. Record LED error code & contact D-Link.
① ② ③ ④ ⑤ ⑥ ⑦ ⑧	Run-Time Program	Download firmware again. Record LED error code & contact D-Link.
① ② ③ ④ ⑤ ⑥ ⑦ ⑧	CPU Memory Failure	Record LED Indicators error code and return the unit.
① ② ③ ④ ⑤ ⑥ ⑦ ⑧	Peripheral Controller Fail	Record LED indicators error code and return the unit.
① ② ③ ④ ⑤ ⑥ ⑦ ⑧	Com Port Failure	Record LED Indicators error code and return the unit.
① ② ③ ④ ⑤ ⑥ ⑦ ⑧	NPB Failure	Record LED Indicators error code and return the unit.
① ② ③ ④ ⑤ ⑥ ⑦ ⑧	PSP Memory Failure	Record LED error code and contact D-Link for support
① ② ③ ④ ⑤ ⑥ ⑦ ⑧	PSP Failure	Record LED error code and contact D-Link for support
① ② ③ ④ ⑤ ⑥ ⑦ ⑧	FEIU Failure	Record LED error code and contact D-Link for support
① ② ③ ④ ⑤ ⑥ ⑦ ⑧	PHY Failure	Record LED error code and contact D-Link for support
① ② ③ ④ ⑤ ⑥ ⑦ ⑧	ARL Failure	Record LED error code and contact D-Link for support
① ② ③ ④ ⑤ ⑥ ⑦ ⑧	ARL Memory Failure	Record LED error code and contact D-Link for support

Table 8: Diagnostic LED

Appendix **A**

DES-5024 Technical Specifications

Switch Specifications

- Complies with IEEE 802.3 CSMA/CD 10 /100-TX, 100BASE-FX and 1000 BASE-SX
- Complies with IEEE 802.1d Spanning Tree
- Switched IEEE 802.3 MAC layer frame size: 64-1518
- NWAY Auto-negotiation for each 10/100-TX network port providing auto-detection of connected cable type, auto-sensing of full and half duplex signaling and auto-configuration
- Cut-Through and Store-and-Forward switching for reliable error-free packet transfers
- Native SNMP management support with Ethernet MIB II (RFC 1213) and bridge MIB (RFC 1493), RMON MIB (RFC-1757)
- 8,192 maximum entries for MAC address Table
- Comprehensive LED indicators display of the system/ port status
- 512KB EEPROM (flash memory) for firmware upgrade
- RS-232 (DB-9) port for Out-of-Band management (asynchronous, 8-bit data, 1 stop bit, no parity, 19.2 K baud)
- Rack mountable (Fits standard 2.5 U EIA 19" rack)
- Two 12-port 10/100 TX modules with built-in support of RMON and VLAN
- Supports Trunking Group
- 2 port fiber optic expansion module with built-in support of RMON and VLAN
- 1 port gigabit expansion module with built-in support of RMON and VLAN

Port Specifications

- 24 RJ-45 ports for Cat 3, 4, or 5 UTP cable (Cat. 5 req. for 10/100-TX)
- 10, 100, 1000 Mbps data transfer rate
- NWAY Auto-negotiation for all 10/100 TX ports
- Full or Half Duplex for all 10/100 ports
- 2 100BASE-FX ports operate at full and half duplex requires 1300 nm mulitmode fiber optic cable, ISO/IEC 793-2 type B-1 and ITU-T G.652 with SC connectors

- 1 1000BASE-SX port, operates at full duplex and requires 850 nm multimode fiber optic cables with SC connectors. This port can also negotiate flow control.

General	
Standards:	IEEE 802.3 10BASE-T Ethernet IEEE 802.3u 100BASE-TX, 100BASE-FX Fast Ethernet and 1000BASE-SX for Gigabit Ethernet ANSI/IEEE Std 802.3 NWAY™ Auto Negotiation IEEE 802.3 Frames types: Transparent IEEE 802.3 MAC layer frame size: 64-1518
Protocol:	CSMA/CD, Full Duplex
Data Transfer Rate:	Fast Ethernet: 100 Mbps (half duplex) 200 Mbps (full duplex) Gigabit: 2000 Mbps (full duplex)
Topology:	Star
Network Cables:	<ul style="list-style-type: none"> • 10BASE-T: 2-pair UTP Cat. 3 (100 m) 4-pair UTP Cat. 4, 5 (100 m) EIA/ TIA-568 150-ohm STP (100 m) • 100BASE-TX: 4-pair UTP Cat. 5 (100 m) EIA/ TIA-568 150-ohm STP (100 m) • 2 Port 100BASE-FX module at 100 Mbps 1300 nm multimode fiber optic cable with SC connectors, ISO/IEC 793-2 type B1 and ITU-T G.652 standards • 1 Port 1000BASE-SX 850 nm multimode fiber optic cables with SC connectors
Number of Ports:	24 x 10/100 Mbps NWAY Ethernet ports plus optional module ports

Physical and Environmental	
AC inputs:	90 – 254 VAC, 50/60 Hz (internal universal power supply)
Power Consumption:	105 watts maximum
DC fans:	2 built in 80 x 80 mm fans and 1 60 x 60 mm fan
Operating Temperature:	0 ~ 50 degrees Celsius
Storage Temperature:	-25 ~ 70 degrees Celsius
Humidity:	5% ~ 95% non-condensing
Dimensions:	441 x 264 x 110 mm (2.5 U), 19 inch rack-mount width
Weight:	6.94 kg 15.3 lbs
EMI:	FCC Class A, CE Mark Class A, VCCI Class A, C-Tick
Safety:	UL (UL 1950), CSA (CSA950), TUV/GS (EN60950)

Performance	
Transmission Method:	Cut-Through and Store-and-Forward
RAM Buffer:	2 M bytes per device
Filtering Address Table:	8 K entries per device
Packet Filtering/ Forwarding Rate:	148810 pps per port (for 100 Mbps)
MAC Address Learning:	Automatic update Max age: five minutes

Index

A

Access Level.....	50, 52
Access Right.....	63
Act.....	29
All LEDs Off.....	78
Audience.....	1
Authentication.....	64

B

Boot PROM Firmware.....	39
Bridge Priority.....	60

C

Cable Specifications.....	18
Cables.....	77
Change Password.....	54
Col.....	27
Cold Start.....	64
Confirm password.....	50
Confirm Password.....	50, 54
Connecting to other devices.....	22
Console Program.....	36
copper cable.....	18
Create New Trunking Port.....	73
Create New User.....	50
Create VLAN.....	68
Cut Through.....	45
Cut-Through.....	44

D

Delete.....	52, 70, 75
Delete Trunking Port.....	75
Delete Users.....	52
Delete VLAN.....	70
DES-5024 to DES-5024 connection.....	22
diagnostic.....	24
Diagnostic LED table.....	77, 79
Duplex.....	26
Dx.....	27

F

Factory Reset.....	38, 42
Features.....	2
fiber module.....	27
fiber optic cable.....	20
Fiber Optic Ports.....	21
Flow Control.....	58
Forget Password.....	78
Forward Delay Time.....	60
Front Panel.....	4

G

General User.....	50
gigabit.....	29

H

Hardware Revision.....	39
Hello Time.....	60
Help Message.....	34

I

Install DES-3216.....	7
Installation.....	8, 9, 11
Installing Modules.....	14
IP Address.....	64

L

LAN Default Gateway.....	40
LAN IP Address.....	40
LAN Subnet Mask.....	40
LED Panel.....	24
Link.....	26, 29
Link Change.....	64
Lk.....	27
Local Console Management.....	6, 31
Log In.....	33

M

MAC Address.....	40
Management Methods.....	6
Max Age Time.....	60
MDI-X Port.....	21
Modify Trunking Port.....	75
Modify VLAN Menu.....	71

N

New Password.....	54
New Trunking Group.....	73
New VLAN Name.....	68

O

Old Password.....	54
Organization.....	1

P

Panel Conventions.....	35
Password.....	50
Physical.....	57
Port.....	68
Port #.....	73
Port State.....	58
Port States.....	77

Ports	21
POST Errors.....	77
Power.....	17
Power LED	24, 77
Priority.....	58

R

Rear Panel.....	5
RMON	6
Root Bridge.....	61
Root Cost	60
Root Port.....	61
Rx.....	27

S

SNMP Community	63, 64
SNMP Management	6, 37, 62, 63
SNMP Setting	63
SNMP Trap.....	64
Software Update.....	39, 46
Software Version.....	39
Spanning Tree	37
Spanning Tree Alg.	60
Spanning Tree Config.....	59
Spanning Tree Config.....	59
STA Operation	59
State.....	57
status.....	24
Status	52, 64, 68, 73
Store and Forward.....	44
Super User	50
Switch Port Configuration	56, 57

System Configuration.....	36
System Configuration Menu	38
System Contact	40
System Description	40
System Information	38
System Information Menu	39
System Location.....	40
System Name	40
System Rate Control.....	38, 44
System Reset.....	38, 41

T

Telnet	6, 32
TrunkGroup	68, 73
Trunking Port.....	75
Trunking Port Management	37, 72
Trunking Port Name.....	76
Tx.....	27

U

User Account Change.....	49
User Account Management	36, 49
User Name	50, 52, 54
Utilization	24

V

Virtual LAN Name.....	71
VLAN.....	66
VLAN Name.....	70
VLAN Port	67
VLAN Port Management.....	37